



G15 CO2 generator

Installer Guide

ENG15EN_EN_V1.2_2023-06-08

Translation of the original manual



Identification

Maker's plate



Introduction

Your Geneglace Ice Machine has been developed and built in compliance with current regulations; manufactured with the greatest care, it has been subjected to permanent quality control. However, if you discover a manufacturing defect, and in order to protect your Geneglace machine, we kindly ask you not to intervene on it and to contact us as soon as possible.

This manual must not be reproduced, even partly, without our prior consent.

The information contained in this manual may be modified without notice.

To help us improve this manual, please inform us of any errors or inaccuracies you may have found therein by sending an email to: contact@geneglace.com

Geneglace SAS cannot be held liable for damage or operating problems on Geneglace machines caused by exceeding the service or safety limits or by using options or expendables other than those approved by Geneglace SAS.



Table of Contents

1. Presentation	7
1.1 Introduction to the manual	7
1.2 Warnings	7
1.3 Looking for information	8
2. Safety instructions	9
2.1 Danger pictograms	9
2.2 Personnel qualification and training	10
2.3 Physical and material dangers	10
2.4 Physical limits of the G15 CO2 generator	11
2.5 Safety instructions	12
2.6 Warnings	13
2.7 Environmental protection	14
3. Pressure equipment safety	15
3.1 Service instructions	15
3.2 Residual risks	15
3.3 Location	15
3.4 Pressure equipment directive 2014/68/EU	15
3.5 Pressure limitation device	15
3.6 Cut-off safety device	16
3.7 Partial pump-down	16
3.8 Permissible limits of pressure equipment	16
4. G15 CO2 generator operation	17
4.1 Normal use of the G15 CO2 generator	17
4.2 Principle of operation of the G15 CO2 generator	17
4.3 Operation of the cooling circuit	19
4.4 Recommended operations	19
5. G15 CO2 generator transportation	20
6. Handling	21
7. Installation G15 CO2 generator	22
7.1 Dimensions	22
7.2 Installing the G15 CO2 generator	23
7.3 G15 CO2 attachments	25
7.4 Ice level security	27
7.5 Ice level control	27
7.6 Installing the ice chute	27
7.7 Protecting the generator against freezing	28
8. Connecting the G15 CO2 generator generator	29
8.1 Hydraulic connections	29
8.2 Electrical connection	32
8.3 Cooling connections	41

9. Operating conditions	46
9.1 Generator G15 with refrigerant R744 (CO2)	47
10. Addition of salt	48
10.1 General Information	48
10.2 Salt doser tube	49
10.3 Salt doser pump	50
11. Options	51
11.1 PGS_2.1 and PGS_2.1 CO2 Electrical panel	51
11.2 Remote control	52
11.3 Ice level detection	54
12. First commissioning	60
12.1 Checks and settings	60
13. Maintenance	66
13.1 Frequency of servicing and monitoring operations	66
13.2 Servicing	68
13.3 Replacing the wearing parts	72
13.4 Adjusting the force limiter	72
13.5 Adjusting the reamer	74
13.6 Adjusting the scrapers	76
14. Troubleshooting	79
15. Exploded views	81
15.1 External Parts	81
15.2 Internal Parts	83
16. First commissioning sheet	85
16.1 Check before powering up	85
16.2 Check after powering up	85
16.3 Check after starting up	86
16.4 After 20 to 30 minutes' operation, check:	86
17. CE Declaration of Conformity	87

1. Presentation



Read the safety instructions carefully before carrying out any work on the ice machine.

1.1 Introduction to the manual

Your Geneglace Ice Machine has been developed and built in compliance with current regulations; manufactured with the greatest care, it has been subjected to permanent quality control. However, if you discover a manufacturing defect, and in order to protect the personnel and your Geneglace machine, we kindly ask you not to intervene on it, to contact the installer and to register the machine

You can contact the Geneglace after-sales service by sending an email to: service@geneglace.com

1.2 Warnings

- The information contained in this manual may be modified without notice.
- It is possible that some images and diagrams do not correspond exactly to the delivered elements.

1.3 Looking for information

Chapter	Description
<ul style="list-style-type: none"> • <i>"Safety instructions" (on page 9)</i> • <i>"Pressure equipment safety" (on page 15)</i> 	These chapters provide information for the installer concerning the safety instructions to be respected before installing a Geneglace machine
<ul style="list-style-type: none"> • <i>"G15 CO2 generator operation" (on page 17)</i> 	This chapter describes all the operating characteristics, factory settings and other settings to be made.
<ul style="list-style-type: none"> • <i>"Handling" (on page 21)</i> 	This chapter provides all the instructions necessary to handle the machine in complete safety
<ul style="list-style-type: none"> • <i>"Installation G15 CO2 generator" (on page 22)</i> 	This chapter describes how to position and install the G15 CO2 generator and the other parts of the machine such as the ice chute and the guards required.
<ul style="list-style-type: none"> • <i>"G15 CO2 attachments" (on page 25)</i> 	This chapter also describes the steps required to ensure that the G15 CO2 generator remains securely in position after it has been installed.
<ul style="list-style-type: none"> • <i>"Connecting the G15 CO2 generator generator" (on page 29)</i> 	.This chapter concerns all the machine hydraulic, electrical and refrigeration connections.
<ul style="list-style-type: none"> • <i>"Cooling diagram" (on page 42)</i> 	This chapter provides the diagrams required to connect the G15 CO2 generator to refrigeration units.
<ul style="list-style-type: none"> • <i>"First commissioning sheet" (on page 85)</i> 	This chapter explains how to start the Geneglace machine for the first time.
<ul style="list-style-type: none"> • <i>"Maintenance" (on page 66)</i> • <i>"Troubleshooting" (on page 79)</i> 	These chapters provide recommendations to keep the Geneglacemachine in optimum working order for as long as possible

Throughout the manual, you will find boxes such as :



The note provides some background information in addition to the subject matter.



The tip suggests procedures to overcome or bypass difficulties that may be encountered.



This insert is intended to draw the reader's attention to particular points that may be relevant to the safety of the worker or the machine.

2. Safety instructions

This manual contains important instructions relating to safety, installation, operation, maintenance and disposal of the ice machines. For this reason you must read the manual before any activity involving the machine.

A maker's plate indicating the type, identification number and other service and safety characteristics of your Geneglace machine must always remain visible and never be removed.







In addition to the safety instructions in this manual, all national or local accident prevention regulations and recommendations must also be observed.

2.1 Danger pictograms



Failure to respect the safety instructions could result in bodily injury and damage to equipment.

The safety instructions provided in the Geneglace SAS manuals are preceded by the following signals:

Pictograms	Meanings
	General danger
	Electrical danger
	Risk of burn
	Danger of crushing
	Chemical danger
	Gas ejection
	Rotation part

2. Safety instructions

These symbols are shown on the machine and the spare parts. Arrows indicate the mandatory direction of rotation. The markings must not be removed and must remain legible.

2.2 Personnel qualification and training

All assembly and servicing operations must be carried out by qualified personnel in compliance with applicable regulations and all current practices and the safety measures of the profession.

Note that all standards as well as local and regional safety regulations, such as European standard EN378, must be taken into consideration during the design, assembly and commissioning of the system.

If the machine is accessible to the public, the site operator is responsible for preventing any accident that could be caused by its mechanical, electrical, or chemical operation.

2.3 Physical and material dangers



No damage claims can be entertained if the safety instructions have not been properly observed.



The G15 CO2 generator assembly is not designed for loads related to snow, wind and earthquake.



Modifications and use of the Geneglace ice machine outside these limits will result in :

- Physical and material damage
- Pollution of the environment
- Cancellation of the warranty

2.4 Physical limits of the G15 CO2 generator

Coolant type:	• According to the configuration of the G15 CO2 : R744
---------------	---



For the other coolants: contact Geneglace

Maxi allowable pressures (PS) :	<i>"Permissible limits of pressure equipment" (on page 16)</i>
Mini allowable temperature	
Ambient air temperature:	+ 10 to + 35°C (dry bulb)
Water quality	Fresh water for human consumption
Temperature of water to be frozen	+ 5 to + 25°C
Water supply pressure	0,6 to 1,5 bars
Supply water hardness	TH 15 to 20° français
Supply water acidity	PH 7/8
Sodium chloride content	100 g/m ³
Protection index:	IP44
Electrical power supply:	Read information on maker's plate and comply with applicable standards.
Value airborne noise	>70 dB



For operation outside these values: contact Geneglace



For further information, refer to the maker's plate in chapter "*Identification*" (on page 3)

2.5 Safety instructions



Before conducting any work, the installation must be locked out/tagged out.



It is prohibited to run the machine without the safety devices originally installed (sensors, housings, etc.)

In the event of problems, maintenance or cleaning operations on the Geneglace ice generator, respect the safety instructions:

1. Before conducting any work, switch off the ice generator using the button provided on the electrical cabinet.
2. Avoid any action on a power outlet or use of an isolating switch installed upline.
3. Lock out/tag out the installation.
4. Perform maintenance or cleaning operations on the ice generator.
5. Before restarting ice production, make sure that all the safety devices operate correctly:
 - Torque limiter
 - Electrical guards
 - Pressure switches
 - Thermostats
 - Transmission guards
 - Covers, hatches in place

These safety devices must be kept in good working order and the danger pictograms must remain visible.



If necessary, maintenance operations will be carried out by the installer with the necessary skill

2.6 Warnings

Warnings	Safety instructions
On/Off button is difficult to access (machine located at height)	<ul style="list-style-type: none"> • Install a second control switch at a more accessible level.
Powering up	<ul style="list-style-type: none"> • Make sure that no employees are near the dangerous areas to avoid possible risks after switching on the electricity supply.
Powering down	<ol style="list-style-type: none"> 1. Switch off the ice machine. 2. Use the isolating switch in the electrical cabinet (three-phase current). 3. Lock out/tag out the installation by placing a padlock on the isolating switch to avoid accidental startup.
The rotating part is driven by a gear reducer and motor coupled by a belt.	<ul style="list-style-type: none"> • Do not operate the ice machine without its safety housings and its safety sensors.
<div style="border: 1px solid red; border-radius: 10px; padding: 10px; background-color: #f8d7da;">  <p>When stopping, the rotating part of the generator continues to rotate.</p> </div>	
Cleaning	<ul style="list-style-type: none"> • Stop and power down the machine. • Secure the installation with a padlock on the disconnecting switch to prevent unintentional switching on. • Do not place the hands or other objects in this area while the rotating parts are still turning.
Working with the cooling circuit communicating with the atmosphere	<ul style="list-style-type: none"> • According to the "MONTREAL PROTOCOL" directives, this operation must only be carried out by qualified personnel.
Operating the valves manually	<ul style="list-style-type: none"> • This operation must only be carried out by maintenance personnel who have the necessary skills (risk of ejection of pressurised fluids).



Main danger areas on the ice generator Geneglace.

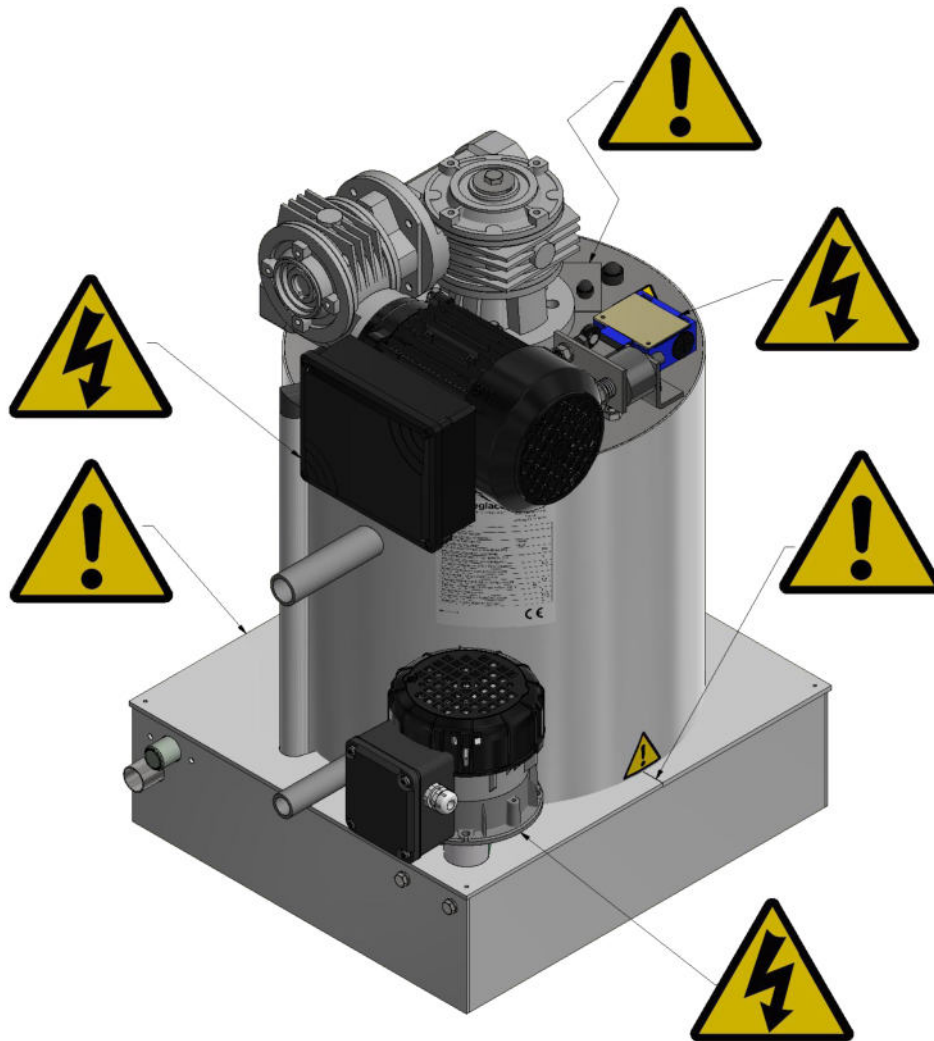

2.7 Environmental protection

Materials and fluids resulting from disposal of the machine must be treated in approved sites in compliance with current regulations.



3. Pressure equipment safety

3.1 Service instructions

3.2 Residual risks

Pressure equipment may result in inevitable residual risks. Therefore, anyone working on this device should read this service instruction carefully and should consider the accident prevention regulations, the generally accepted safety regulations, the EU directives and the specific provisions of the country concerned.

3.3 Location



Geneglace ice generators should not be used as a coolant storage tank.



The G15 CO2 generator Geneglace must be transported in strong packaging to its installation location.

The G15 CO2 generator Geneglace is a unit designed to be installed in the "low pressure" parts of refrigeration systems and indoors, protected from the weather.

Suitable protective measures must be taken if the machine is used in extreme conditions (e.g. aggressive atmosphere, extreme outside temperatures, etc.). It is advisable to consult Geneglace.

3.4 Pressure equipment directive 2014/68/EU

Ice generators Geneglace are pressure equipment that comply with the Pressure Equipment Directive 2014/68/EU.

Consequently,

- the entire installation must be declared to and authorised by an inspection organisation, in compliance with local applicable regulations.
- An EU declaration of incorporation and conformity is provided with the pressure equipment.
- The installer must comply with Geneglace SAS installation and operating manuals.
- The operator must submit this equipment to periodic requalification inspections in compliance with the regulations applicable in the country of installation.



In countries outside the EU, local regulations must be applied.

3.5 Pressure limitation device



There must be no shut-off devices at the valve outlet.

3. Pressure equipment safety

An overpressure protection system in accordance with EN ISO 4126 and EN 13136 or the relevant local regulations must be installed, the elements necessary for the calculation are indicated in the chapter "*Limites admissibles des équipements sous pression*" (sur la page1).

3.6 Cut-off safety device

In accordance with current local regulations, cut-off safety devices must be provided to limit pressure or temperature (thermostats and safety pressure switches).

3.7 Partial pump-down

Do not install a pump down on the generator.

3.8 Permissible limits of pressure equipment

Permissible limits for "Geneglace generator only" pressure equipment :

Type		Volume (L)	PS (Min/Max) (Bar)	T° (Min/Max) (°C)
G15 CO2		1,8	-1/+27	-30/+45

Type	Coolant	D.E.S.P. Category	Coolant group	Load (kg) (kg)	T. eq CO2
G15 CO2	R744	Art. 4.3	2	0,5	0,001

4. G15 CO2 generator operation

This chapter describes the operating principles of the G15 CO2 generator generator and of the cooling circuit.

4.1 Normal use of the G15 CO2 generator

The G15 CO2 generator Geneglace is designed to produce dry and subcooled flake ice from drinking water.

4.2 Principle of operation of the G15 CO2 generator

Simplified cross-section of a generator

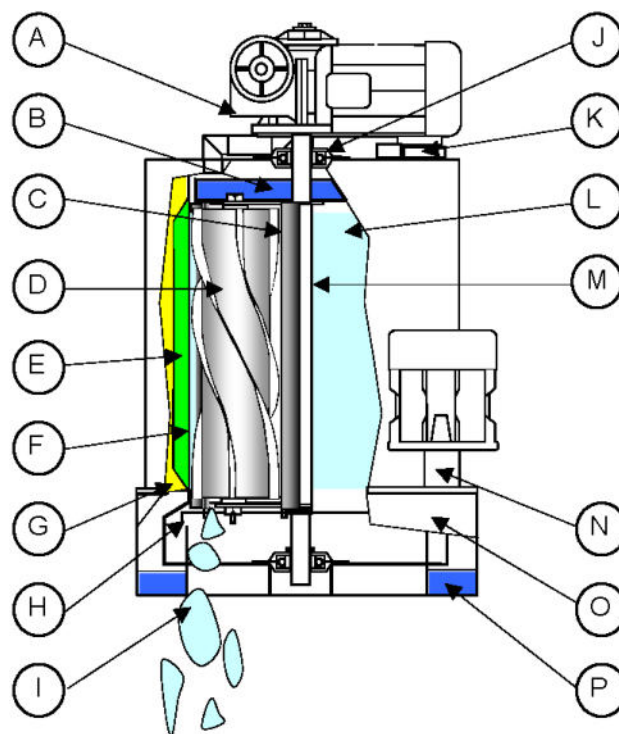

Water distribution plan view

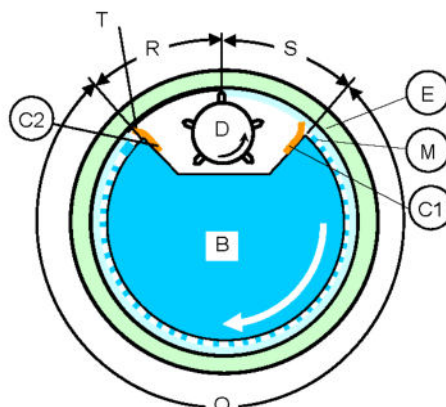

4. G15 CO2 generator operation



DANGER: DO NOT MOVE THE REAMER AWAY FROM THE CYLINDER, this could cause:

- Bearing wear
- The torque limiter safety device to trip
- Liquid hammer and oil leaks that could destroy the compressor



DANGER: DO NOT CHANGE THE SPEED OF ROTATION OF THE REDUCER, this could cause operating problems. The speed of rotation of the reducer is set in the factory



The ice thickness does not depend on the distance between the reamer and the cylinder.

The thickness and quantity of ice produced by the ice generator depend on:

- The generator cooling power,
- The evaporation temperature,
- The speed of rotation of the reducer.

Operating principle:

1. The water distributed by the bowl **B** flows abundantly and permanently on the inner surface of the fixed cylinder **F**.
2. In the fixed cylinder **F**, low-temperature coolant flows in the double wall **E**.
3. The cylinder insulation **G** ensures that all the cooling power is transmitted to the water and the ice.
4. Some of this water is frozen **M**.
5. The excess frozen water returns via the recovery bowl **H** into the base **O**.
6. In the base **O**, the level **P** is kept constant by a float valve (not shown).
7. This water is circulated by the pump **N**.
8. The helical reamer **D** driven by a gear reducer **A** sweeps the surface **L**.
9. The helical reamer **D** rotates due to the thickness of the ice and removes the ice by simple pressure.
10. For proper operation, the distance between the reamer and the cylinder must be **less than 0.4 mm** without the reamer coming into contact with the cylinder.
11. The torque limiter **K** switches off the gear reducer electricity supply in case of excessive stress on the reamer.
12. The spraying area **Q** is defined by two scrapers **C1** and **C2**, on each side of the reamer **D**.
13. The scraper **C1** in front of the reamer, dries the ice before it reaches the subcooling area **S**.
14. The ice removal area **R** is located between a tooth of the reamer **D** and the rear scraper **C2**.

4. G15 CO2 generator operation

15. There must be no water in areas **R** and **S** between the two scrapers to produce good quality ice and ensure that the machine operates correctly.
16. The scraper **C2** provides a seal between areas **R** and **Q**.
17. However, a trickle of water **T** of about 1 mm must flow along the rear scraper **C2** on its front side at the junction with the cylinder.
18. The ice is evacuated down the ice chute **I**, ready for use.

4.3 Operation of the cooling circuit

1. The coolant flows in a fixed, sealed double wall (see *"Principle of operation of the G15 CO2 generator" (on page 17)*)
2. The coolant (pressure reduced previously) is injected via the branch connection on the lower part of the cylinder.
3. The coolant enters the double wall and changes from liquid to gaseous state.
4. This evaporation absorbs the heat brought by the water running over the inner wall of the cylinder, turning it into ice.
5. The heat exchange takes place through the inner wall of the generator and the coolant is never in contact with the water to be frozen.
6. The coolant is pumped and regenerated by a condensation unit and regenerated by a condensation unit.

To ensure that the ice machine operates correctly, make sure that the flow rate of reduced pressure coolant injected into the generator is controlled to obtain optimal and constant filling of the generator via the adjustment devices. (See *"First commissioning sheet" (on page 85)*)

4.4 Recommended operations

- If the generator is fitted with its own compressor, leave the electricity switched on when the machine is stopped: the compressor housing heating element must always be powered up.
- Similarly, after a prolonged power cut, switch on the power at least 3 hours before starting ice production.
- Avoid stopping and starting the machine for short periods of time.
- Allow the machine to operate for 4 consecutive hours rather than alternating 4 times 1 hour on and 1 hour off.
- During prolonged stops (more than one week), operate the generator for 1 hour without adding salt, then drain and dry the base before stopping the G15 CO2 generator.
- Managing an ice tank: the basis used to calculate the useful volume is: about 500 kg of fresh ice flakes for 1 m³ storage.
- Over time, the ice quality deteriorates. For optimum ice quality, adjust ice production to match consumption.
- The ice tank must be emptied at least once a week, otherwise the ice might be difficult to remove with a risk of damaging the Geneglace ice machine due to ice going up in the generator.

5. G15 CO2 generator transportation



The G15 CO2 generator should be transported in secure packaging to its installation location.

The centre of gravity of the G15 CO2 generator is offset from its base. It should be transported in its original packaging and remain bolted to the pallet until it is unpacked.

The location of the G15 CO2 generator must be strong enough to support its weight.

6. Handling



The ice machine must only be handled by qualified personnel.



Toutes les précautions seront prises afin d'assurer la sécurité des personnes et d'éviter tout risque de chute et d'endommagement du G15 CO2 generator pendant la manutention.

The dimensions and strength of the slings must be adapted to the load to be handled

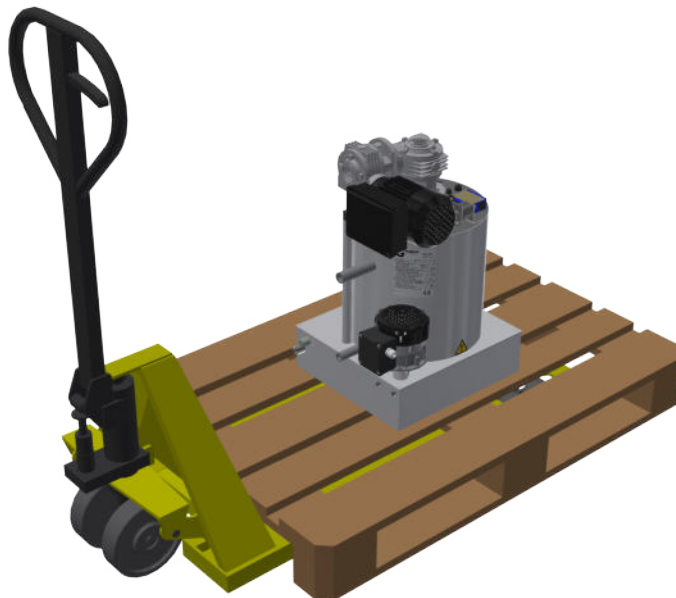

Generator	Net weight
G15 CO2	50 kg (110 lb)

7. Installation G15 CO2 generator



Operations to be carried out in accordance with the recommendations given in chapter "*Safety instructions*" (on page 9)



Risk of freezing when the machine is stopped: protect the generator as indicated in chapter "*Physical limits of the G15 CO2 generator*" (on page 11)



The installation site of the G15 CO2 generator must be strong enough to support its weight.

7.1 Dimensions



Reserve sufficient access for servicing and maintenance of the ice machine.

7. Installation G15 CO2 generator

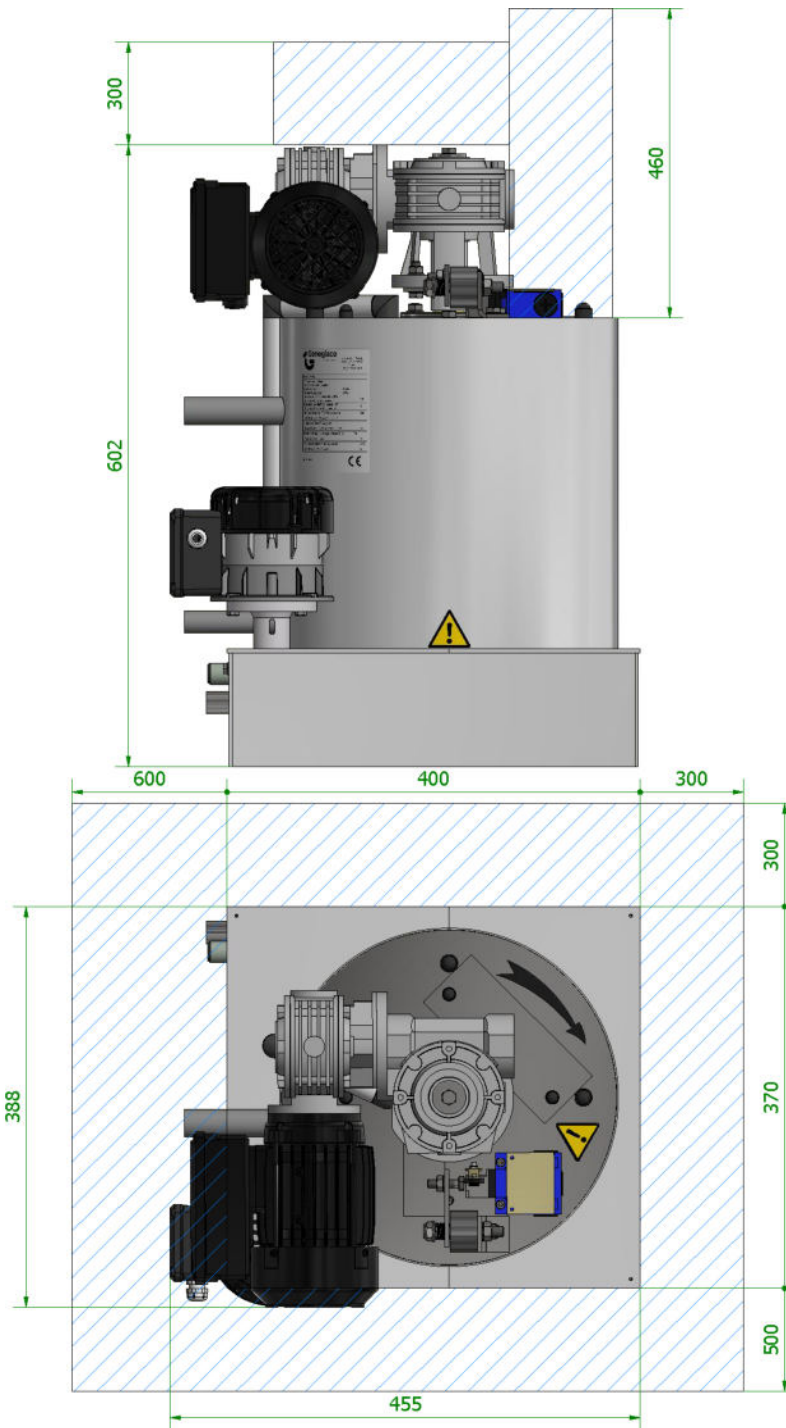

Values in millimetres

7.2 Installing the G15 CO2 generator

Once you have chosen its location, you can install the generator.

1. When selecting the location of the G15 CO2 generator, avoid pressure differences between the G15 CO2 generator and the storage room. There must be no air circulation in the generator.

7. Installation G15 CO2 generator

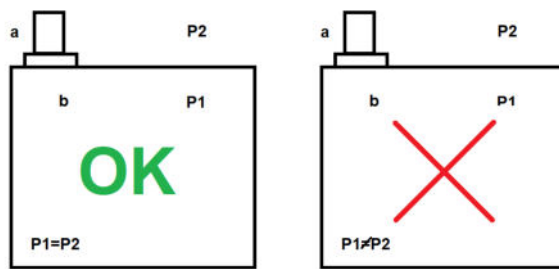

a=Generator room

b= Storage room

P1=Storage room pressure

P2= Generator room pressure

2. Place the generator on a flat, level surface, preferably on a coaming.
3. Place the generator in a non aggressive environment and protected from:
 - bad weather,
 - dust,
 - splashes of water or any other liquid product.
4. Position the generator leaving sufficient access for servicing and maintenance (see "*Dimensions*" (on page 22) for the minimum servicing space).
5. Position the generator high enough to allow suitable storage for its daily ice production (e.g. cold room, static or orbital silo, etc.).
6. Do not locate the ice output in the air flow of an evaporator.
7. Do not reduce the cross-section of the generator ice output.



Remember to leave access above and below the machine to simplify all servicing and maintenance work on the generator

7. Installation G15 CO2 generator

7.3 G15 CO2 attachments

1. The opening in the generator support must be at least equal to the ice chute diameter "G".

7.3.1 Positioning of fasteners

The unit is mounted by the bottom of the base using the two holes provided for this purpose.

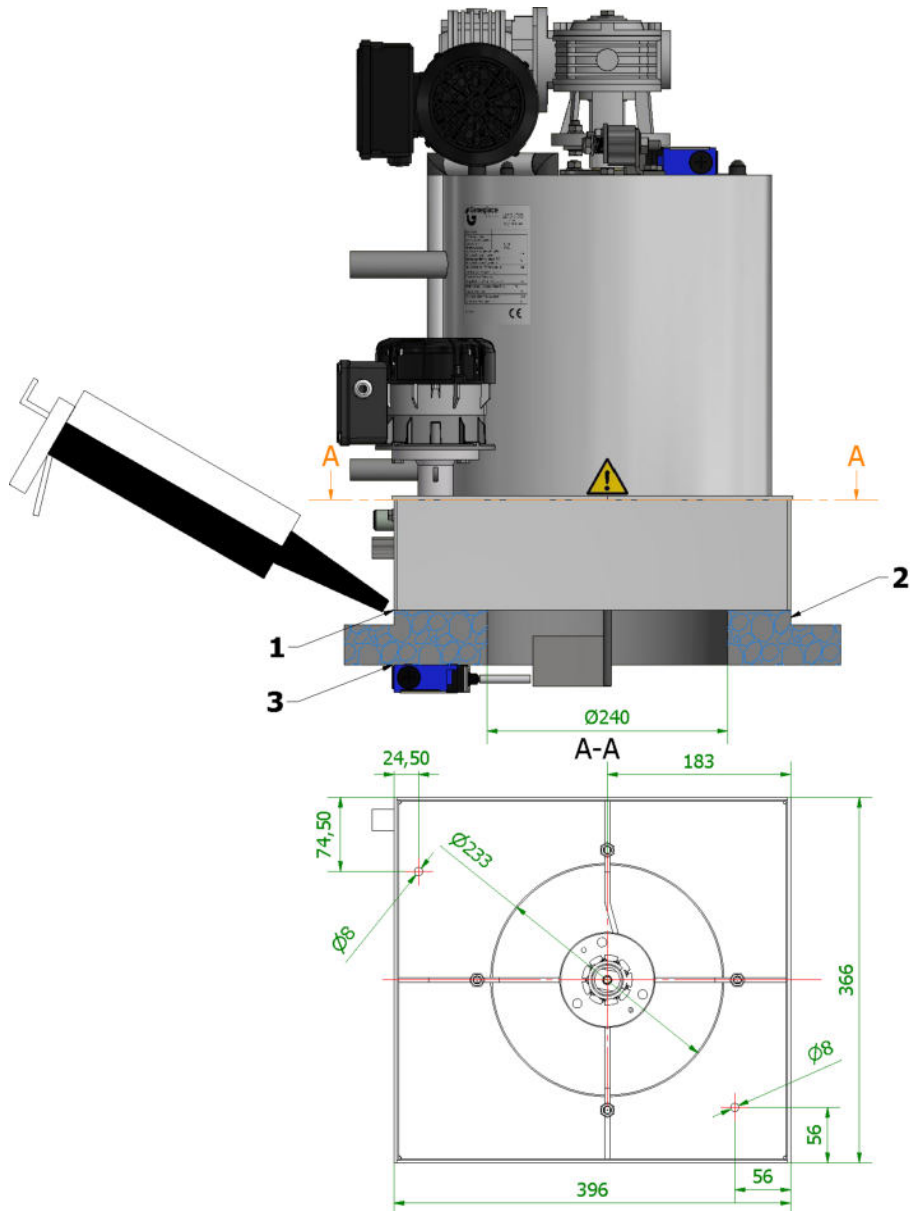

Values in millimetres

7. Installation G15 CO2 generator

7.3.2 Fixations types



Do not forget to add a silicone seal all round the base of the generator to prevent water entering the ice storage area.

Fibre seals ensure the mountings are watertight.

- Wood or concrete support :

In the case of a wood or concrete support, we recommend the following method of fixing :

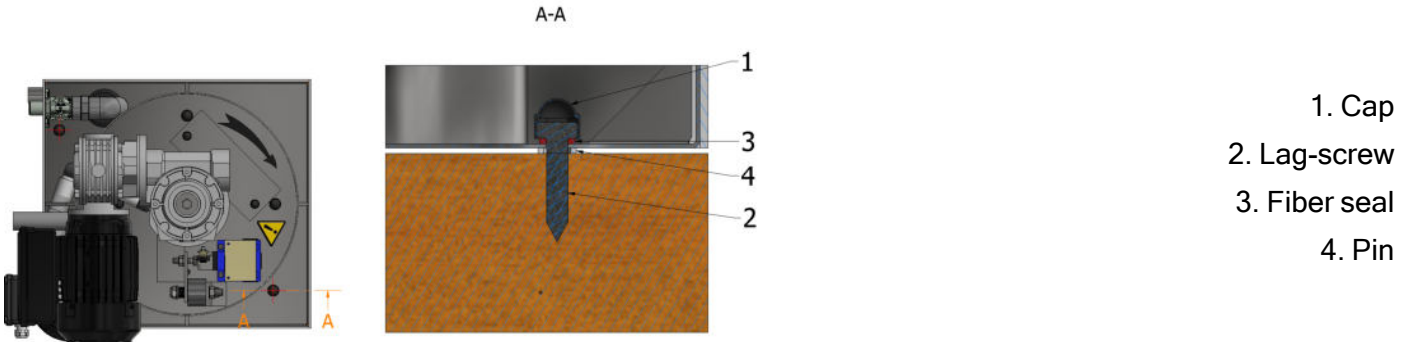

1. Cap
2. Lag-screw
3. Fiber seal
4. Pin

- insulated wall :

In the case of an insulated wall, we recommend the following method of fixing :

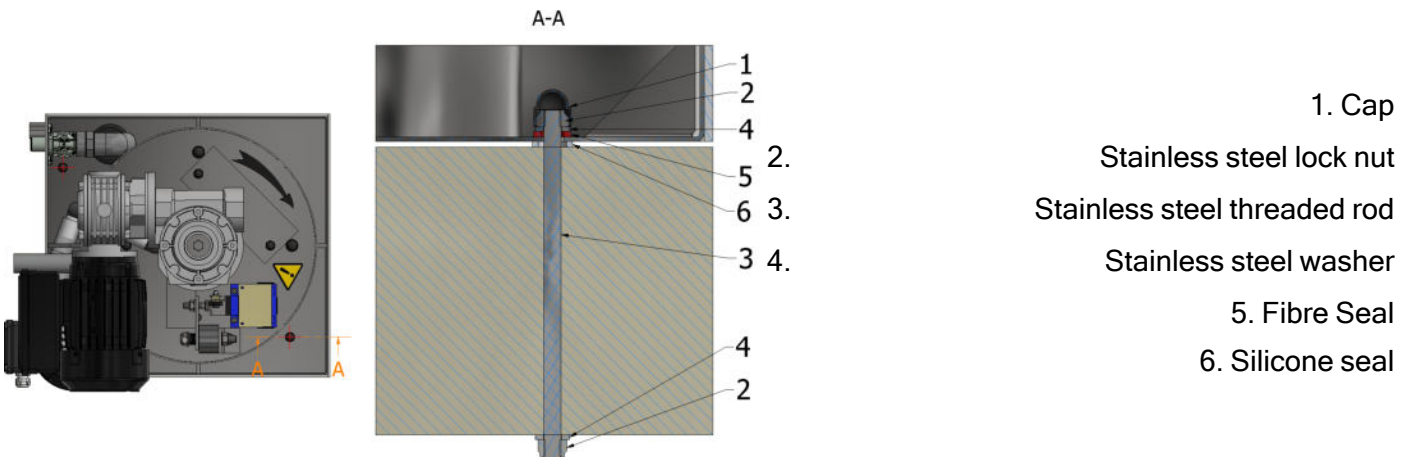

1. Cap
2. Stainless steel lock nut
3. Stainless steel threaded rod
4. Stainless steel washer
5. Fibre Seal
6. Silicone seal

7. Installation G15 CO2 generator

7.4 Ice level security



If there is a risk of ice rising, install an ice level sensor.



For more information see *"Ice level detection"* (on page 54)

7.5 Ice level control

To use the highest quality ice, adjust the ice production as closely as possible to the ice consumption with an ice level control sensor.



For more information see *"Ice level detection"* (on page 54)

7.6 Installing the ice chute

After installing the generator, make sure that the ice chute is installed correctly.

Follow the instructions to install the chute correctly.

1. Make sure that the chute can be dismantled easily.
2. Choose a material which prevents the ice flakes from sticking. (PVC recommended)
3. Do not incline the chute more than 45°.
4. Do not reduce the cross-section of the generator ice output.
5. Make sure that there is an overflow space of at least 100 mm at the top of the chute to prevent the ice from going up in the generator.

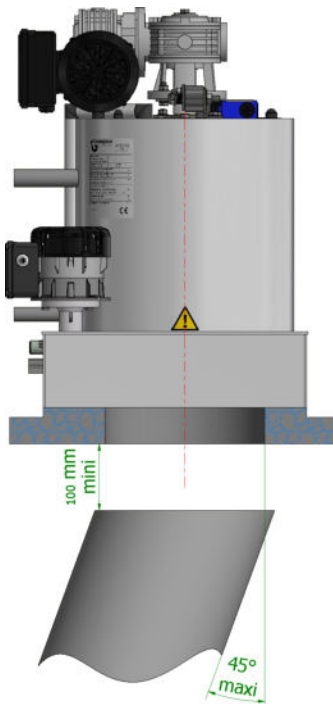

7. Installation G15 CO2 generator

7.7 Protecting the generator against freezing

- Upstream from the installation, protect the water supply against freezing.
- Downstream from the installation, protect the water evacuation against freezing.

For further information, refer to "*Physical limits of the G15 CO2 generator*" (on page 11)

8. Connecting the G15 CO2 generator generator

8. Connecting the G15 CO2 generator generator



Operations to be carried out in accordance with the recommendations given in chapter "Safety instructions" (on page 9)

8.1 Hydraulic connections

8.1.1 Hydraulic characteristics

Generator G15 CO2

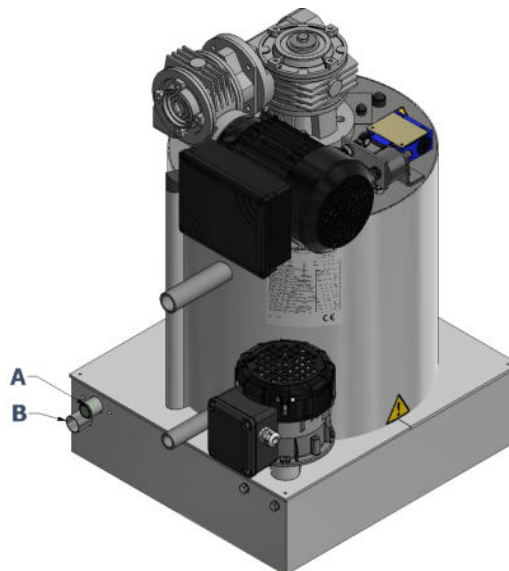

Generator	Ref.	Designation	Qty	Connections		
				Dimensions	Type	Material
G15 CO2	A	Water supply	1	1/2 " gaz	Threaded	PVC
	B	Overflow	1	20/22 mm	Smooth tube	Stainless steel

8.1.2 Connecting the water supply



To avoid malfunctions of your ice machine, remember to install the following devices:

- Water pressure control
- Water filtration or purification
- Protection against loss of water or water supply

8. Connecting the G15 CO2 generator generator

1. Install water filtration or purification devices.

Filtering the water supply can reduce the rate of impurities deposited in the Geneglace ice generator, but not scale build-up.

2. Install a water treatment system when the water hardness exceeds the recommended limits (refer to *"Physical limits of the G15 CO2 generator" (on page 11)*)
3. Make sure that the water supply pressure complies with the recommended values (refer to *"Physical limits of the G15 CO2 generator" (on page 11)*)
4. Check that the water flow rate is always constant and greater than that required for ice production.
5. Install a flexible tube to connect the water supply.



The water consumption of your Geneglace ice machine is equal to its ice production.



Plan a valve on the water supply to simplify the maintenance operations.

8.1.3 Connecting the overflow

If the float valve malfunctions, excess water is evacuated via the overflow.

The overflow prevents water from overflowing through the ice chute evacuates water from the base.

1. The overflow water must be sent down the drains, as stipulated by regulations.
2. The evacuation pipe must have no rising section which could prevent the natural flow of water.
3. The slope of the evacuation pipe must be sufficient to allow the natural flow of water.

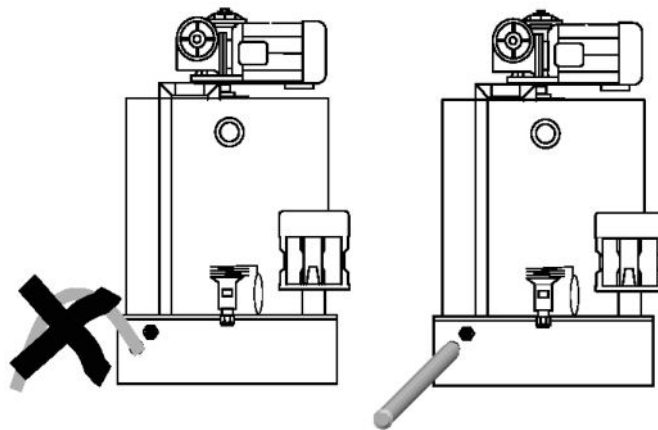

8. Connecting the G15 CO2 generator generator

8.1.4 Prevention measures for hydraulic connections

Risks	solutions
Risk of frost upstream and downstream from the machine installation	Fit the water supply and evacuation pipes with devices protecting them against freezing.
The supply water is too hard	Install a water treatment system
The water flow rate is not constant and remains less than the generator water consumption rate.	Install a pump with a tank.



The overflow must accept the flow from the tap



A water meter can be installed to monitor the machine ice production

8. Connecting the G15 CO2 generator generator

8.2 Electrical connection



In all the following cases, do not forget to connect the earth terminal.

8.2.1 Electrical characteristics



The cross-section of the electrical supply cable must be suitable for the installed power of the machine (see Maker's plate).

Electrical power supply:

The type of electricity supply is indicated on the maker's plate attached to the generator.

Make sure that the electricity supply of the Geneglace ice machine complies with applicable regulations and the following characteristics:

- Voltage (Volts)
- Three-phase or single-phase + earth
- Frequency (Hz)
- Installed power (kVA)
- Nominal current (A) An electrical box ensures the control and operation of the G15 CO2 generator. The electrical box respects the electrical sequences recommended by Geneglace "*Diagramme de fonctionnement*" (Page 1).

Electrical cabinet:

An electrical box is required to monitor the operation of the generator.

It must respect:

- The electrical sequences recommended by Geneglace, refer to "*Operating diagram*" (on page 37).
- The applicable regulations.



Geneglace proposes an optional electrical box (Refer to "*Le coffret électrique PGS_2.1 et PGS_2.1 CO2*" (sur la page1))

An electrical box ensures the control and operation of the G15 CO2 generator. The electrical box respects the electrical sequences recommended by Geneglace "*Diagramme de fonctionnement*" (Page 1).

Electrical protection device

The electrical protection devices in compliance with applicable standards must protect all the machine actuators.

8. Connecting the G15 CO2 generator generator

Generator G15 CO2

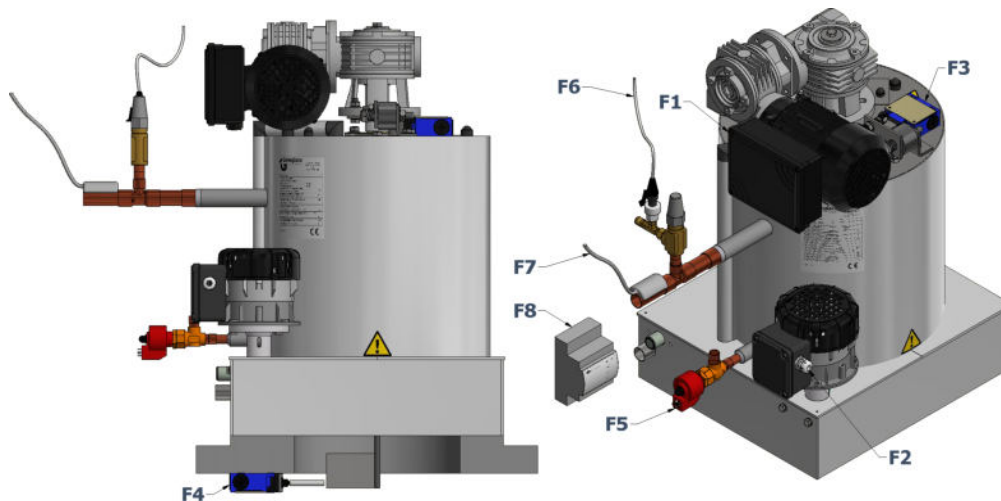

Ref.	Designation	Qty.	Electrical power supply	Nominal power	Nominal current	Contact
F1	Scraper motor	1	400V - 3 - 50Hz	90W	0,62A	-
	Scraper motor	1	230V - 1 - 50Hz	110W	1,2A	-
F2	Water pump	1	230V - 1 - 50Hz	16W	0,14A	-
F3	Torque limiter contact	1	-	-	-	1NC/1NO
F4	Ice level safety contact	1	-	-	-	1NC/1NO
F5	Pressure reducer	1	24V	-	-	-
F6	Pressure sensor	1	-	-	-	-
F7	Temperature sensors	1	-	-	-	-
F8	Driver	1	24V	-	-	-

8. Connecting the G15 CO2 generator generator

8.2.2 Single-phase electric motor

In the case of a 220 Volt single-phase supply, the scraper motor has a 10 μf capacitor.

The connection is as follows:

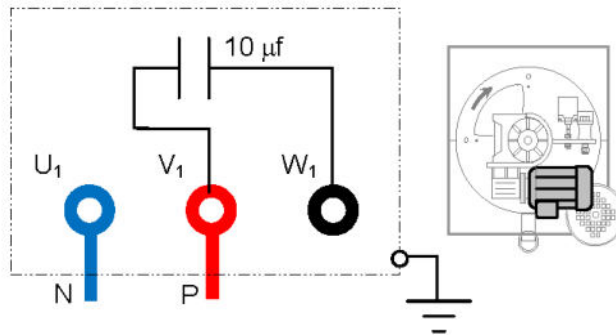

If all the moving parts do not rotate in the direction indicated by the arrow on the upper part, then connect the phase to W1.

8.2.3 Three-phase electric motor

In case of three-phase power supply, make the correct coupling according to the characteristics of the electricity source.

400 V three-phase coupling to be made

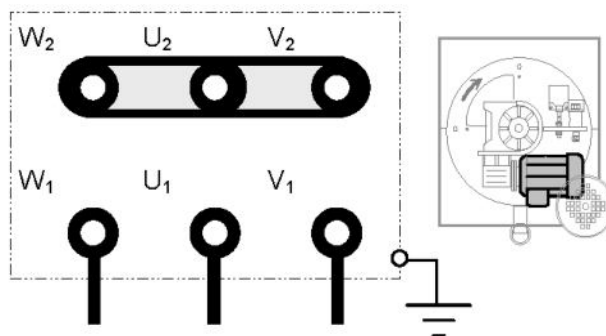

If all the moving parts do not turn in the direction indicated by the arrow on the upper part, then reverse 2 phases (ex: W1 and U1)

8.2.4 Water pump

The water pump runs on 230 V single-phase and is already fitted with a cable.

Respect the colours of the cable conductors.

- Neutral (blue)
- Phase (brown)
- Earth (green/yellow)

8. Connecting the G15 CO2 generator generator

8.2.5 Torque limiter contact

The diagram below shows the state of the torque limiter contact when the generator is operating normally.

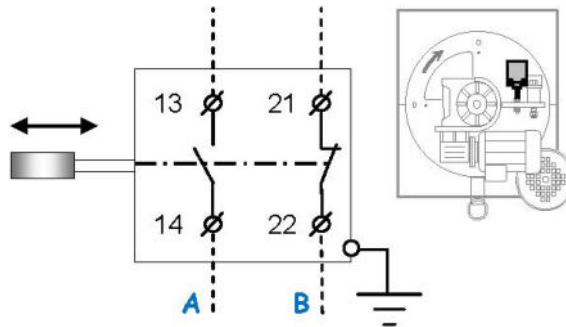

- A. Fault indication
- B. Action on the security chain

8.2.6 Electronic pressure reducer

In the case of a G15 CO2, the generator is equipped with an electronic pressure reducer.

- Electronic pressure reducer with connector, 6 m cable (installed)
- Pressure sensor with connector, 5 m cable (installed)
- 6 m long temperature sensor (to be installed)
- Driver set by Geneglance(to be installed)

1. Install the sensor according to the following diagram:

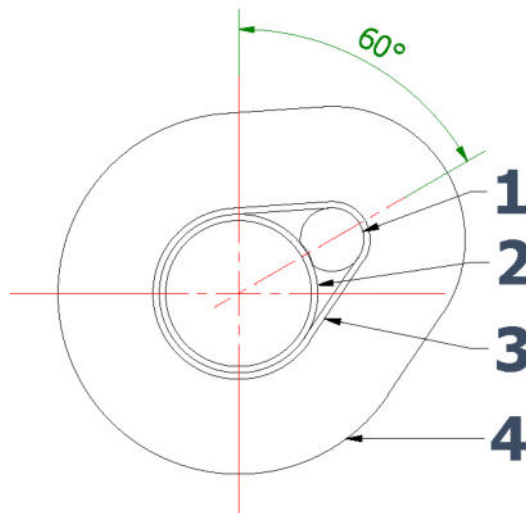

8. Connecting the G15 CO2 generator generator

Rep	Désignation
1	Sonsor
2	Pipework
3	Fixing clamp
4	Insulation

2. Install the driver in the electrical box in accordance with the standards in force.



If the electrical box option is supplied with the generator then the driver is already installed.

3. Connect the driver according to the following diagram:

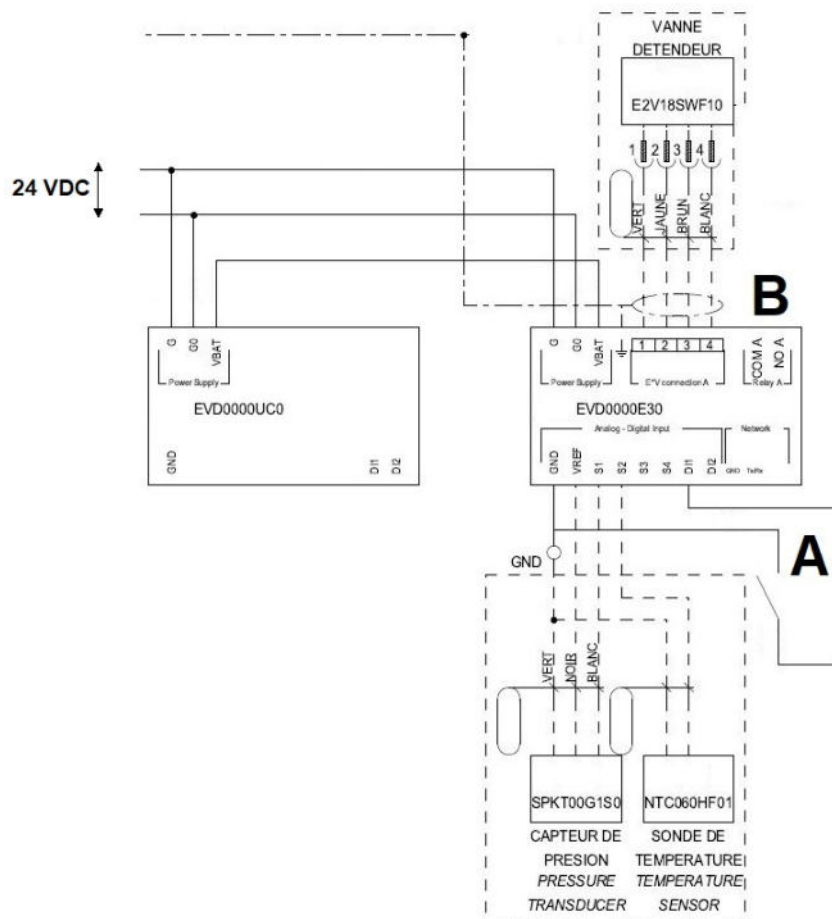

A

Running demand

B

Alarm signal

8. Connecting the G15 CO2 generator generator

8.2.7 Operating diagram

8.2.7.1 General Information



Automatic restarting is PROHIBITED after resetting a safety device.

The electrical sequences must be adapted to the type of installation.

Safe tripping of the torque limiter,, or the scraper motor circuit breaker must simultaneously:

- Stop the water pump
- Stop the scraper motor
- Close the liquid solenoid valve
- Stop the generator condensation unit if one is connected
- Stop the salt doser pump (option)



To preserve your machine, install an anti-short cycle



To simplify the maintenance operations, install manual operation switches inside the electrical cabinet for the scraper motor, water pump and salt doser pump .

Timeout	Description	Duration
Timeout T1:	Time between powering up the liquid solenoid valve and filling 3/4 of the cylinder with coolant. Setting according to the installation	0 s to 180 s
Timeout T.KA1	Temps nécessaire pour le nettoyage du cylindre après arrêt du générateur	180s

8. Connecting the G15 CO2 generator generator

8.2.7.2 Generator connected to a refrigeration unit



Do not install a Pump down on the

ON/OFF button	I O				
Liquid solenoid valve	I O				
Scraper motor	I O				
Water pump	I O				
Salt doser pump (option)					
Timeout		T1		T KA1	

8. Connecting the G15 CO2 generator generator

8.2.7.3 Generator connected to a condensation unit

When the ice machine is switched on, the following items start at the same time:

- The compressor,
- The liquid supply solenoid valve,
- The water pump,
- The gear reducer.
- Salt Dosing Pump(Optional)

If the condensing unit is outside or far from the generator, it may be necessary to set a delay in starting the gear motor and the water pump. This delay ensures that at least 3/4 of the height of the generator is filled with fluid at start-up.

T1 with a question mark (?) indicates that it does not always have to be installed if the condensation unit is close to the generator.

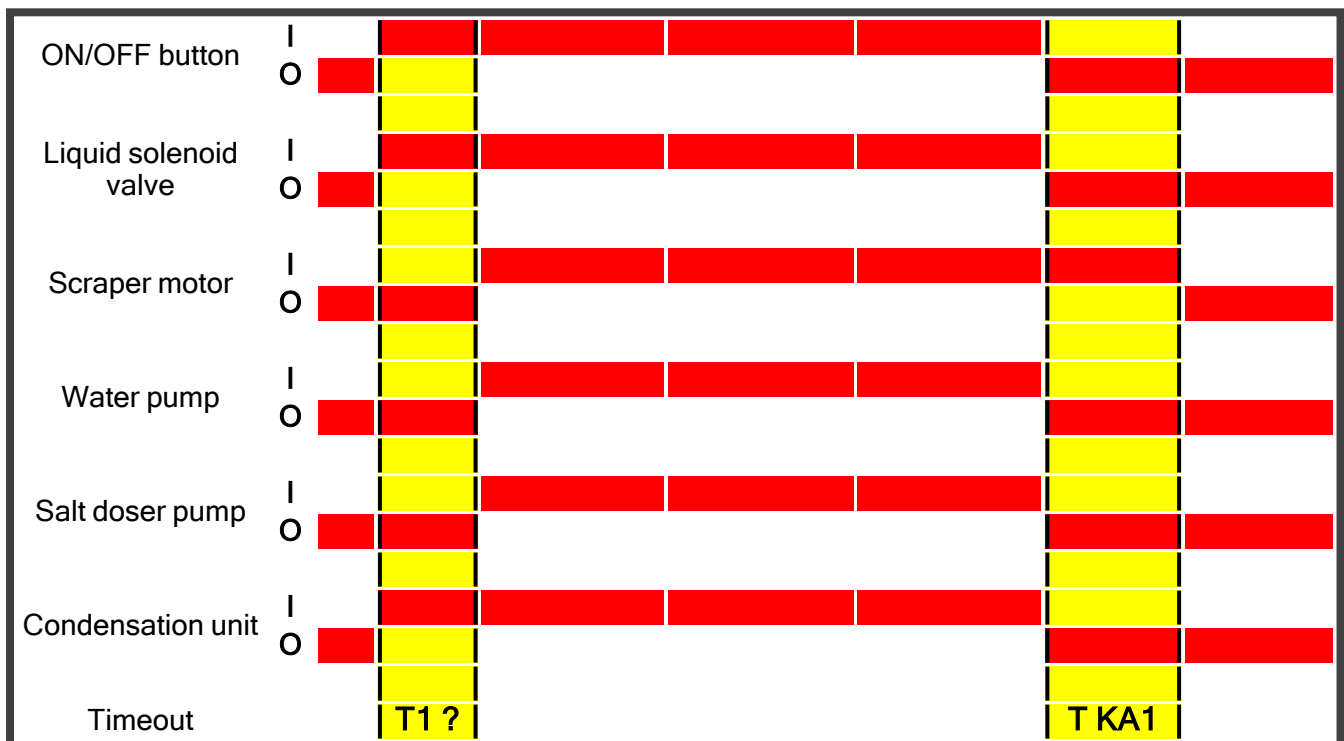

8.2.7.4 Automatic starting and stopping

For an automatic start and stop, a first request for start must be made by pressing the start push button on the PLC.

Redo a request if the G15 CO2 generator has been switched off.

Ice production can be controlled by a clock. The operating time is estimated according to the possible capacity of the ice tank (approx. 500 kg/m³) and the hourly production rate of the machine.

To control the height of ice in the storage tank, it is recommended to install infrared or laser distance sensors.

To prevent ice production from accidentally stopping or starting, we recommend installing a timeout to acquire the signal from the sensor.

If the ice level detection or the clock cut out, the machine stops automatically according to the standard procedure

8. Connecting the G15 CO2 generator generator

If the ice level detection or the clock cut in, the machine starts automatically according to the standard procedure



Refer to "*Recommended operations*" (on page 19)

8. Connecting the G15 CO2 generator generator

8.3 Cooling connections



Every precaution will be taken to ensure that the refrigeration piping complies with professional standards: clean, favouring the return of oil to the compressor...



See "Pressure equipment safety" (on page 15).

8.3.1 Cooling characteristics

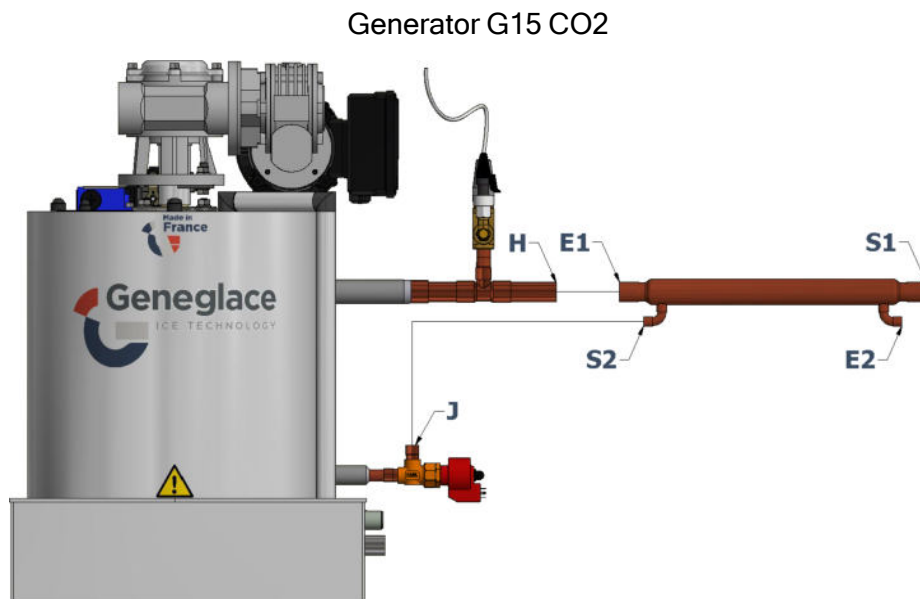

Ref.	Designation	Qty.	Connections	G15 CO2
E1-S1	Heat exchanger Suction line	1	Dimensions	7/8"
			Type	O.D.F.
			Material	Copper
E2-S2	Heat exchanger Liquid line	1	Dimensions	3/8"
			Type	O.D.M
			Material	Copper
H	Suction	1	Dimensions	7/8
			Type	O.D.M
			Material	Copper
J	Liquid supply	1	Dimensions	1/2"
			Type	O.D.M
			Material	Copper

8. Connecting the G15 CO2 generator generator

8.3.2 Cooling diagram



For the Maximum Allowable Operating Pressure (PS) refer to chapter "*Permissible limits of pressure equipment*" (on page 16), and to the manufacturer's identification plate on the generator.



Provide adequate safety systems to prevent pressure rises above the Maximum Allowable Working Pressure (PS), according to the regulations in force.



If the generator is likely to be isolated from the rest of the cooling circuit by isolation valves:

- It is essential to install a safety valve to protect the generator.
- The generator must be systematically drained each time before closing these valves.



When incorporating the G15 CO2 generator into the rest of the refrigeration circuit, a pressure resistance and leakage test shall be carried out at a PT value **less than or equal** to the factory applied PT test pressure by Geneglace. This value is indicated on the generator nameplate in chapter "*Identification*" (on page 3)

8. Connecting the G15 CO2 generator generator

8.3.2.1 Generator with exchanger

The generator with exchanger is designed to be connected to a refrigeration system supplying the generator with HP liquid.

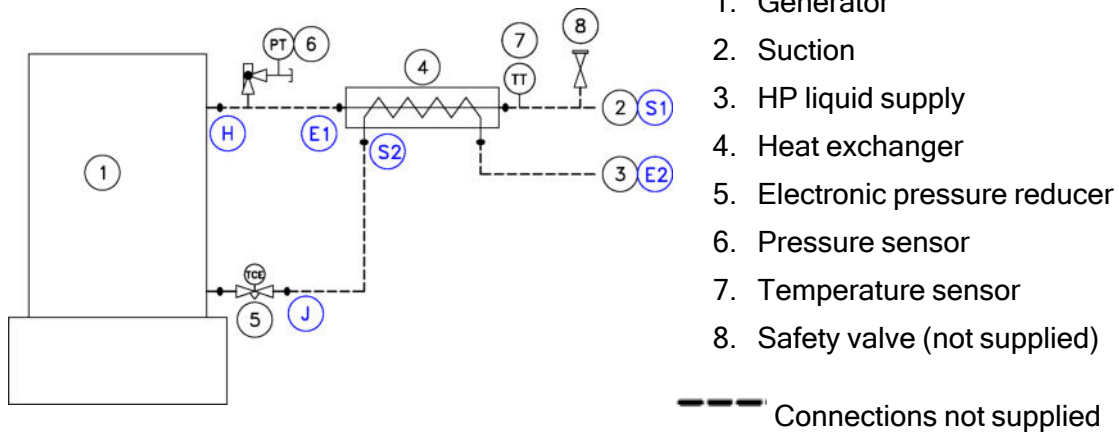

8. Connecting the G15 CO2 generator generator

8.3.3 Liquid and suction lines



Every precaution will be taken to ensure that the refrigeration piping complies with professional standards: clean, favouring the return of oil to the compressor...

1. Align the liquid and suction pipe connections at the same level at the generator or heat exchanger connections
Incorrect alignment could cause the pipes to crack and/or break.
2. The pipes must be fixed at regular intervals. These fixings must rest on a mounting which prevents the pipes from moving and absorbs vibrations.
For safety reasons, do not use the pipes as a step or support for other equipment.
3. For the suction line, make sure that the pressure drop between the generator and the compressor is as low as possible (to be taken into account for calculations).

8.3.4 Compressor

The refrigeration compressor must be fitted with a casing resistor.

8.3.5 Generator and refrigeration unit located at the same level

For the pipe diameters, refer to tables "*Dimensions*" (on page 22) and "*Connecting the G15 CO2 generator generator*" (on page 29).

The stated pipe diameters can be kept for a maximum developed length of 6m (236 inch) . The performance may drop in this case.

8.3.6 Generator and refrigeration unit located at different levels

If the compressor and the generator are located at different levels, take care when connecting the pipes.

8.3.6.1 Suction line



The piping must avoid any oil retention



The suction piping must slope downwards towards the compressor.



To facilitate technical interventions, it is advisable to install a pressure test connection on the suction pipe at the generator outlet.

If the suction piping rises, then:

1. Install an oil trap at the evaporator outlet.
2. Install a trap every two or three metres (79 to 118 inches) of rising piping.
3. For the suction piping sloping downwards towards the compressor, place an inverted trap at the top end to prevent any oil return.

8. Connecting the G15 CO2 generator generator

4. If the suction piping is very long after a section of rising piping designed to guarantee correct oil return, go back to a larger cross-section to minimise the head losses.
5. Insulate the suction piping in accordance with best practices:
 - Minimum thickness 13 mm (0,5 inch), to be adapted according to ambient conditions
 - Water vapour must not be allowed to migrate through the insulation to prevent rotting of the insulation and corrosion of the tube. (e.g. use of grease tape).



Note that all local safety standards and regulations, such as European standard EN378, must be taken into consideration during the design, assembly and commissioning of the system.

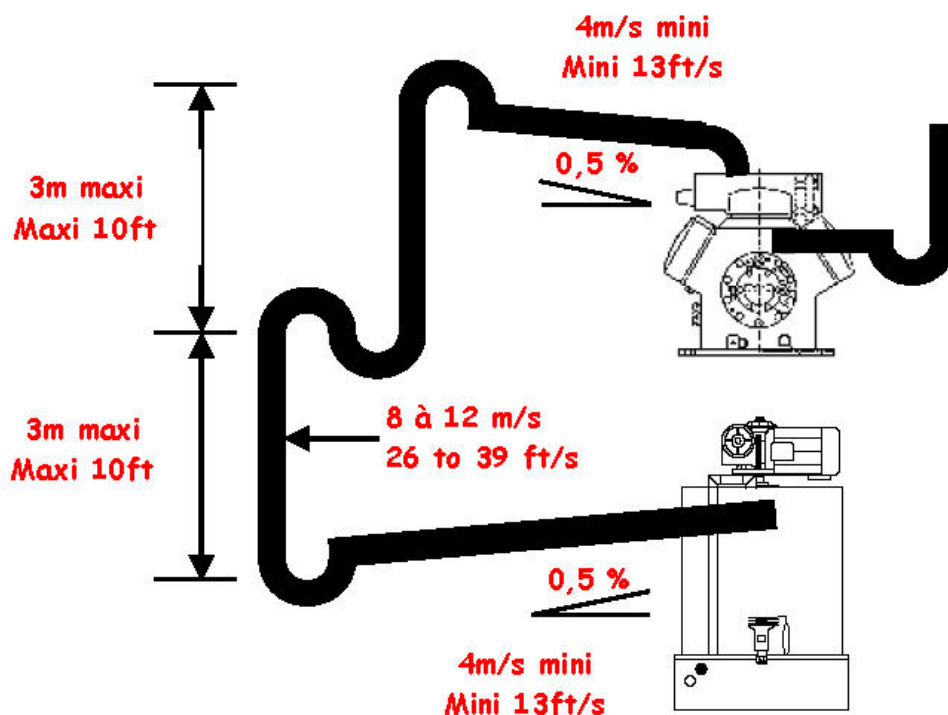

8.3.6.2 Liquid line

1. Any gas trap, any section of piping in an inverted "U" must be avoided to prevent interruption of the liquid flow.
2. Where the difference in level is greater than approximately 5m (197 inches):
 - it is recommended to increase the diameter of the liquid piping.
 - Reconsider the selection of the expansion valve, taking into account the **pressure upstream** from the pressure reducer.

8.3.7 Assembly on refrigeration unit

Minimum refrigeration equipment to be provided by the installer:

- Safety valve according to local regulations.
- Constant pressure valve with manometric plug **if necessary**.

9. Operating conditions



Do not operate the generator outside the operating ranges specified by Geneglace SAS. See



The stated production values are given for an oil-free cylinder.



For the production values and speeds not indicated, contact Geneglace SAS for a more precise definition.



Before using any coolant other than those indicated in this manual, contact Geneglace SAS.



Geneglace SAS reserves the right to make any modifications or improvements to the data in this chapter without prior notice.

9.1 Generator G15 with refrigerant R744 (CO₂)

Characteristics	Units			
Approx. load	kg	<i>"Permissible limits of pressure equipment" (on page 16)</i>		
Water to be frozen	°C	15		
	°F	59		
Production	T /24h	0,700	0,720	0,730
	UST/24h	0.77	0.79	0.80
Cooling capacity	KW	3,5	3,6	3,7
	BTU/h	11942	12283	12624
Frequency	Hz	50		
Speed of rotation	tr/h	121	121	121
Thickness of ice flakes	mm	2	2,1	2,1
	inch	0.08	0.08	0.08
Evaporation temperature at the generator	°C	-23,6	-25,5	-26,5
	°F	-10,48	-13,9	-15,7
Frequency	Hz	60		
Speed of rotation	tr/h	116	116	116
Thickness of ice flakes	mm	2,1	2,2	2,2
	inch	0.08	0.08	0.08
Evaporation temperature at the generator	°C	-25	-27,2	-28,6
	°F	-13	-16,96	-19,48

10. Addition of salt

10.1 General Information

The operation of a flake ice machine is improved by adding sodium chloride to the water to be frozen.

Salt addition function:

- Delays scaling if hard water is used.
- Produces larger flakes with less broken flakes or "snow".
- Makes it easier to scrape off the ice and minimises the forces produced by reaction on the gear reducer.
- Helps to rebalance the supply water if soft water is used.

Overall, the result is large ice flakes and more "flexible" operation.

Adding salt:

Two systems:

- The standard doser using tablets calibrated to diameter 25mm (0.98 inch), used in softeners for resin regeneration.
- The doser pump using salt dissolved in water in PVC tanks.

The quantity of salt consumed:

- 80 to 100 g per tonne of ice, normal quantity, to be corrected depending on the water characteristics.

The ice quality:

- The presence of very small ice flakes indicates a lack of salt, often a sign of soft water.
- The presence of very large ice flakes which can break off before the reamer goes past is a sign that there is too much salt.

10.2 Salt doser tube



The salt doser tube is the salt addition system mounted in series, if you did not order the salt doser pump option.

The salt doser tube is attached to the generator cylinder by two collars.

1. It consists of a rigid transparent tube closed at its bottom by a drilled plug held by a collar.
2. A small metal tab collects the water trickling through the bottom of the cylinder, to guide it to the doser tube.
3. The water collected flows between the tube and its plug.
4. The water comes into contact with the salt tablets.
5. This method generates a drip of salted water through the hole of bottom **No. 3**.
6. The doser tube is installed in a corner of the base and positioned so that the bottom **No. 3** is 70mm (2.7 inch) from the bottom of the base and so that the tab is directed towards the central shaft of the generator.
7. Hole **No. 1** fits on the head of the screw of the top collar.
8. Raise the bottom **No. 3** or reduce the inclination of tab **No. 4** to reduce the salt consumption of the G15 CO2 (and vice versa)

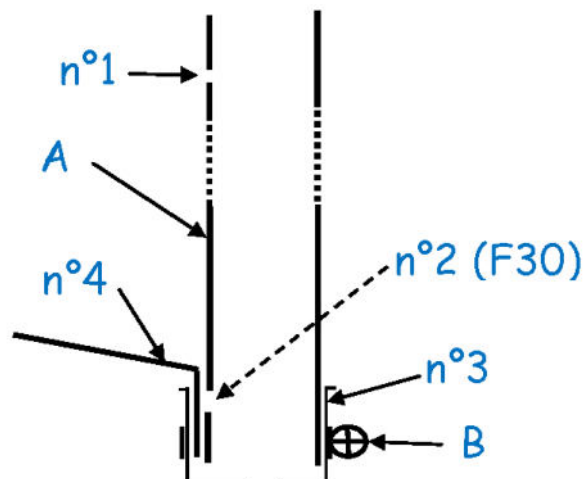

A. Collar

Precautions required when using these systems:

- The tablets used in standard dosers must be perfectly cylindrical with at rounded ends so that they do not jam in the vertical tube.
- The tube must remain vertical after being filled.
- Adjusting the flow rate requires great care.
- The bottom of the doser must be cleaned every month to maintain correct operation.

10.3 Salt doser pump



If your Geneglace ice generator is equipped with a salt doser tube using tablets, the doser pump is not supplied.



Refer to the salt doser pump manual - 02 933 070 included with the salt doser pump.

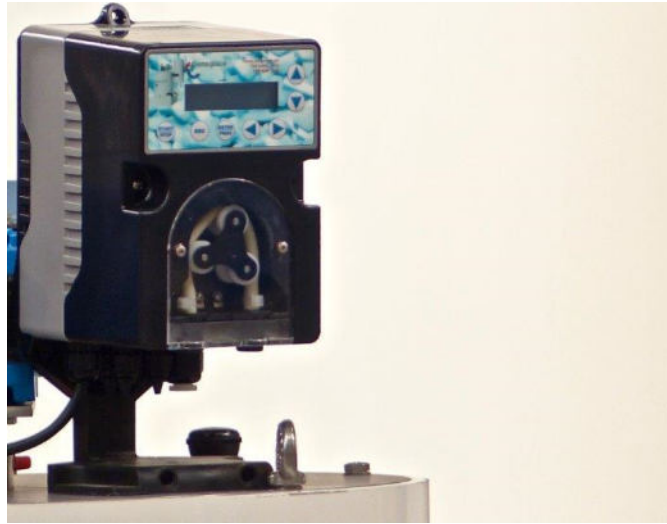

The doser pump must operate during ice production.

The electrical characteristics are as follows:

- Power supply 100÷240 Vac - 50/60 Hz - 15 W
- Flow rate range: (0.1 % to 100%)x 2 L/h.
- IP65
- Fuse 1.6 A (20 W).

11. Options

The options concern all the peripherals of the ice machine related directly to its operation, proposed by Geneglace SAS.

11.1 PGS_2.1 and PGS_2.1 CO₂ Electrical panel



Refer to the *PGS2.1 and PGS_2.1 CO₂* electrical panel manual supplied with the electrical box

As standard, the box is designed for a three-phase + neutral power supply.



This manual describes the operation of the Electrical Panel PGS_2.1 + CIP from the PGS V6 program of the PLC. (See electrical diagram in the Electrical Panel PGS_2.1 + CIP)

The Electrical Panel PGS_2.1 + CIP is used to control the generator electrical operating sequences Geneglace.

The Electrical Panel PGS_2.1 + CIP can be used in the following configurations:

- A refrigeration unit supplying several direct expansion evaporators, including the generator Geneglace.
- A refrigeration unit supplying several forced recirculation evaporators, including the generator Geneglace.
- A refrigeration unit dedicated to the generator Geneglace.
- A cascade refrigeration supply for the generator Geneglace.

The Electrical Panel PGS_2.1 CO₂ electrical box is used for G15, G30, G100 generators connected in direct expansion on a CO₂ installation. In this version, the box is equipped with a DRIVER (configured by Geneglace SAS) controlling the generator electronic pressure regulator.

The communication between the generator Geneglace and the condensation unit remains the same.



Code Article	Description
02 500 354	DOUBLE ELECTRICAL BOX F15 to G100 - CO2
02 500 373	PGS_2.1 ELECTRICAL BOX 400V-3+N-50Hz G15 to G100 CO2
02 500 381	PGS_2.1 ELECTRICAL BOX SPLITPACK
02 500 397	PGS_2.1 ELECTRICAL BOX 400V-3-50Hz G15 to G100 CO2
02 500 374	PGS_2.1 ELECTRICAL BOX 230V-1+N+T-50Hz G15 to 30 CO2
02 500 094	OPTION CIP/400 V-3-50Hz

11.2 Remote control

Option article code: 02 534 003



11.2.1 Use

The remote control option is a box used to start and stop ice production remotely.

The remote control option is mainly used when the electrical box is not easy to access.

The remote control option is consists of:

- An On button
- An Off button
- A green On indicator light
- A red fault indicator light
- An emergency stop button

The remote control box must be connected electrically to the generator box alone.

11.2.2 Weekly programmable clock



The clock programming manual is provided in the remote control box together with the wiring diagram.

Using a weekly programmable clock, the remote control option can be used to postpone the ice production.

The clock is a digital time switch controlled by a microprocessor.

11.2.3 Assembly

The remote control box must be installed in a place that is easy to access by the generator operator.

11.2.4 Connection

The remote control box must be connected to the generator electrical box according to the wiring diagram supplied in the Electrical Panel G15 CO2 generator .

11.3 Ice level detection

Ice level detection is used to :

- To secure the ice production from a rise of ice in the generator
- Regulate the height of the ice in the ice storage.

Geneglace offers:

- To secure ice production:
 - An infrared sensor detector.
- To control the height of the ice in the storage:
 - An infrared sensor detector.
 - An ice level indicator with high and low level control

11.3.1 Ice level detector with infrared sensor.

11.3.1.1 Safety and control detection characteristics.



If the infrared sensor dedicated to the control is not supplied, consult Geneglace.
Example: installation with another ice control system.

For the ice level detection option with ice production, Geneglace provides :

- 1 Infrared sensor for security level
- 1 Infrared sensor for the control level
- 1 Support for 2 detectors per infrared sensor.



The infrared sensor for the security level and the infrared sensor for the control level are identical.

Code Article	Quantity	Characteristics
OGDDNB	2	Infrared sensor 10-30 V DC IP67
	1	Ice level sensor support

11.3.1.2 Operating principle of the infrared safety sensor



Automatism to be realized if electric box not supplied by Geneglace SAS.

1. The infrared security sensor is directed horizontally towards the ice outlet of the generator and monitors the presence of ice in this area.
2. The infrared security sensor allows to secure the ice production from ice rising in the generator.
3. When ice is detected in the area and after an adjustable timeout, the infrared security sensor triggers the contact to stop the ice production in ice level security.
4. If the ice level in the ice storage system decreases and the infrared security sensor no longer detects the presence of ice at the generator outlet, the system does not restart automatically. The security shutdown information for ice level remains active.
5. Adjustable timeout prevent the contact from being triggered by a single ice chip passing the detector.

11.3.1.3 Operating principle of the infrared ice level control sensor



Automatism to be realized if electric box not supplied by Geneglace SAS.

1. The infrared level control sensor is directed towards an ice heap and measures the distance between the top of the ice heap and the infrared area.
2. The infrared level control sensor is used to set a cut-off level which corresponds to the height of ice required in the storage tank.
3. Once the ice height has been reached and after an adjustable timeout, the infrared level control sensor closes the contact requesting ice production to stop.
4. When the height of ice in the storage tank drops below the cut-off level set, after an adjustable timeout, the infrared ice control sensor closes the contact requesting ice production to start.
5. The adjustable timeouts prevent the contact from closing if a single ice flake goes in front of the infrared level control sensor.

11.3.1.4 Installation of the infrared sensors

1. The infrared sensors are installed on the same support.
2. The infrared detection area must be directed horizontally towards the ice generator outlet for the security infrared sensor and vertically towards the ice slope for the level control infrared sensor.
3. When selecting the position of the infrared sensors, take into account the angle of slope formed by the flake ice in the ice storage.

4. Position the infrared sensors to avoid ice rising in the ice generator cylinder.
5. The infrared sensors should not be placed directly in the ice fall but as close as possible to the ice fall and protected from the falling flakes.
6. The infrared level control sensors must be installed inside the ice storage.
7. Make sure that the cables of the infrared control sensors pass through the wall and that there is no water on the sensors.

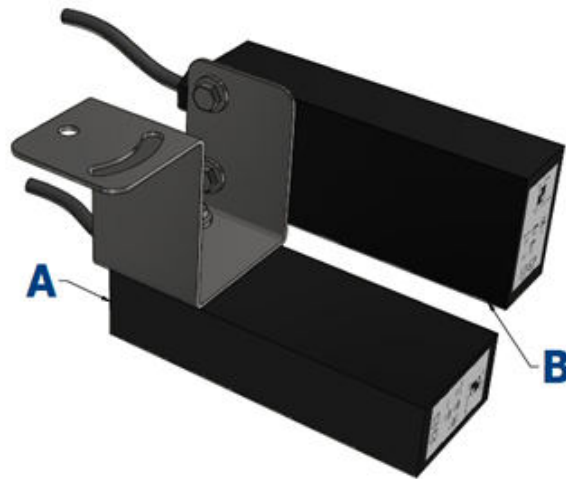
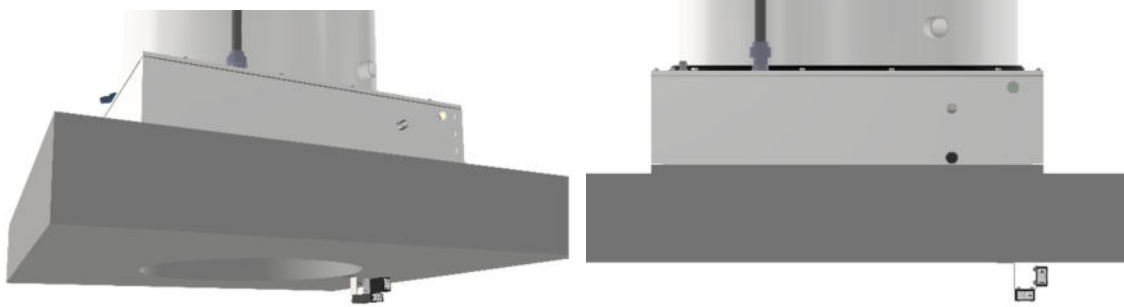

A: Infrared sensor for safety level

B: Infrared sensor for the control level

11.3.1.5 Connection

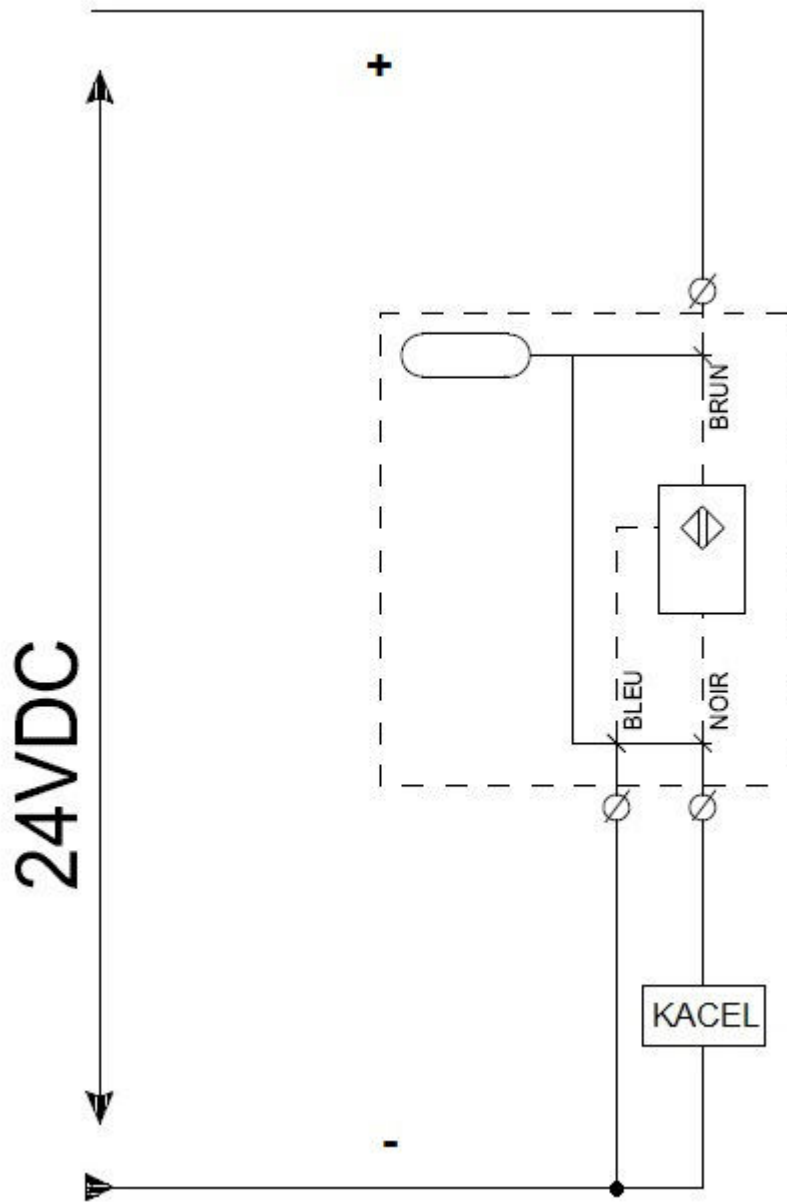

KACEL= Cell relay (not supplied)

11.3.1.6 Adjustment of the infrared control sensor

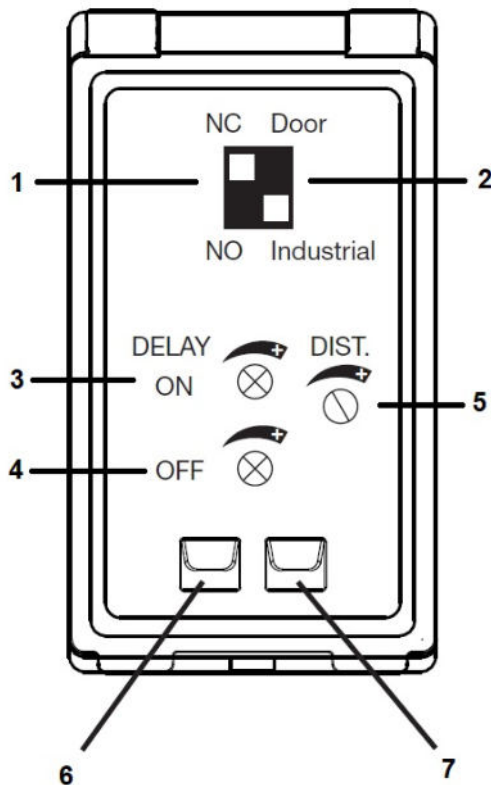

1. Contact type (**NC** or **NO**)
2. Detector moder (**Door** or **Industrial**)
3. Output timeout **ON**
4. Output timeout **OFF**
5. Distance adjustment
6. Output indicator light
7. Power supply indicator light

1. Switch on the infrared sensor detector, the power supply indicator light (7) comes on.
2. Set the contact type (1) depending on your application. If you are using a PGS_2 electrical box, select **NC**.
3. Set the detector mode (2) to **Industrial**.
4. Set the output timeouts **ON** (3) to maximum (16 seconds).
5. Set the output timeouts **OFF** (4) to maximum (16 seconds).
6. Adjust the cut-off level with the distance adjustment potentiometer (5) depending on the height of ice required in the ice storage tank (from detector 50 to 2500 mm).
7. When the ice level is detected, the output indicator light (6) flashes until the end of the output timeout **ON** (3) and stays lit.
8. When the ice level is no longer detected, the output indicator light (6) flashes until the end of the timeout **OFF** (4) and goes out.

11.3.2 Ice level indicator with high and low level control



Refer to the attached *Ice level indicator with high and low level control* manual with the ice level indicator control.

11.3.2.1 General information

The G15 CO2 generator Geneglace is an option providing digital display of the ice level in a storage unit.

1. An analogue level detector with a vertical laser continuously measures the height of the ice at a point in the storage silo.
2. The measurement is converted to a **4-20mA** electrical signal and sent to a digital display.
3. The display interprets the **4-20mA** signal and displays the corresponding height on a digital readout.

The display unit is fitted with two dry contact relays that can be actuated independently according to the configured ice levels. This function is used mainly for starting and stopping the production of ice fed to the storage unit, thereby avoiding superfluous filling in periods of low ice consumption.



The display may be incorrect if the laser beam of the detector is deviated by the position of an ice flake.



Depending on the position of the analogue level sensor in the ice storage, the number of ice production, the ice quality or the slope of the ice slope, the ice level display may not reflect reality.

If the option is ordered when purchasing a new installation. Then the level indication is shown on the PLC display as a bar graph. In this case, the analogue level is tested and set at the factory. (See Silo AOS Manual)

As an option, it is possible to connect a box equipped with a digital indicator in order to report the ice level display.

The "Ice Level Indicator" box complements the "Ice Level Indication" option on the automatic orbital silo cabinet.

The "Ice Level Indicator" box displays the ice level in the automatic orbital silo.

The "Ice Level Indicator" box must be installed so that it is visible to users.

11.3.2.2 List of the ice level indicator supplies

The G15 CO2 generator Geneglace option, is composed of the following components:

- Distance sensor
- Cable 5 m (16.4 ft) connector M12
- Detector mounting bracket
- Ice level indicator box

12. First commissioning



All first commissioning operations must be carried out by qualified personnel in compliance with applicable regulations and all current practices and the safety measures of the profession. Refer to "*Personnel qualification and training*" (on page 10)

This chapter describes the chronology of checks and actions required before, during and after the first commissioning of your Geneglace ice machine in complete safety.

Consequently, before starting your Geneglace ice machine, refer to the recommendations provided in this chapter, by putting an X in the boxes corresponding to the checks you have performed (see "*First commissioning sheet*" (on page 85)).

At this stage, the machine is in position, installed and connected in compliance with our recommendations.

12.1 Checks and settings

The G15 CO₂ generator is tested in the factory, but due to the sometimes random transport conditions, a check of the electrical and hydraulic parts of the G15 CO₂ generator is still necessary.

12.1.1 Electrical checks

12.1.1.1 Electrical panel checks

- Set all the circuit breakers to the values corresponding to the nominal current absorbed by their respective motors.
- Set or preset the timeouts:
 - If a Geneglace panel (option) is used, refer to "*PGS2 and PGS2 CO₂ electrical panel manual*"
 - If an electrical panel not supplied by Geneglace is used, refer to "*Operating diagram*" (on page 37)

12.1.1.2 Gear reducer checks

- Start the gear reducer
- Check that the rotating parts rotate in the direction shown by the arrow on the top of the generator. If the direction of the motor is reversed, make the change to the electric motor supply as described in chapter "*Single-phase electric motor*" (on page 34) or "*Three-phase electric motor*" (on page 34)
- Check that the speed of rotation of the gear reducer corresponds to the machine selected.



The gear reducer speed is the number of complete turns made by all the rotating parts within one hour.

12. First commissioning

12.1.1.3 Torque limiter checks

- Start the gear reducer
- Check that the torque limiter works correctly by making it trip, holding the roller of its electrical contact **A**.
- Reset the torque limiter by holding the gear reducer with both hands and rotating it a few degrees clockwise **B**.

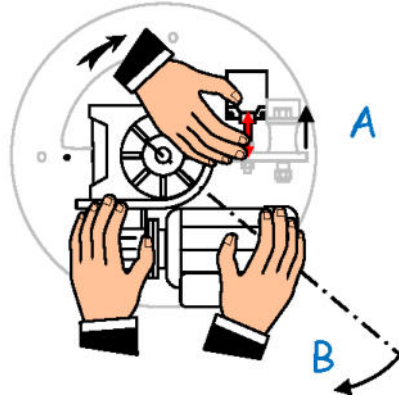

12. First commissioning

12.1.2 Hydraulic checks

- Check that the water supply rate is greater than the quantity of water required for maximum production of your Geneglace generator and that the water quality is adequate.
- Check that the water supply pressure of your machine corresponds to the value indicated. *"Physical limits of the G15 CO2 generator" (on page 11)*
- Check, by pressing the valve float, that water enters the base.

12.1.2.1 Presetting the float valve



Whether the machine is running or stopped, the water must never overflow out of the base overflow.

The water level in the base must be high enough to avoid pump cavitation due to insufficient water, but not too high to avoid water going through the overflow.

Water level in the base		G15 CO2
Maximum level when stopped	mm	50
	inch	1,97
Minimum level during operation	mm	40
	inch	1,57

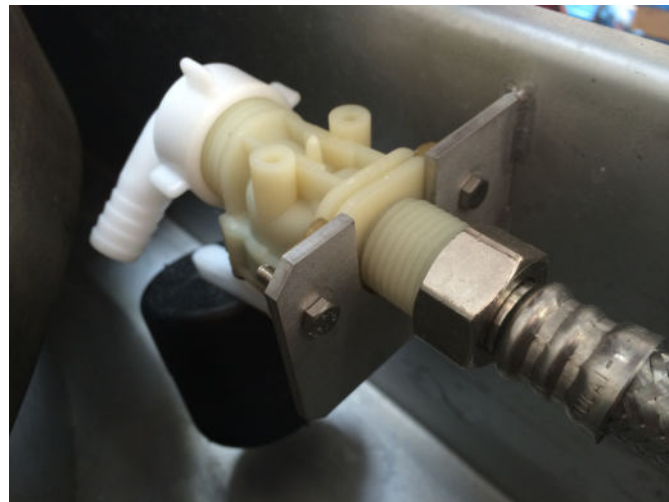

The first time the machine is used, immerse the float so that the water level is nearly up to the overflow, to help prime the pump.

12.1.2.2 Levels in the distribution bowl

On the G15 CO2 generators, the water level in the distribution bowl is obtained by the output from the water pump and by adjusting its overflow tube.

12. First commissioning

To check the water level, switch on the water pump alone after checking that there is sufficient water in the base.

- The water level must be minimum 15 mm **A** and maximum 1 mm below the indent at the top of the bowl **B**.
- In this case, check that the water is at the same level as the overflow tube of the distribution bowl and flows out from it permanently.

Correct level

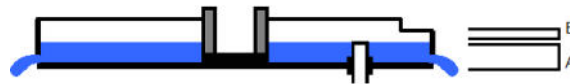

If the water level in the distribution bowl is too low, raise the overflow tube or refer to chapter "*Adaptation de la pompe à eau*" (Page 1).



- If the water level in the distribution bowl is much too high, check that the holes in the bowl are not blocked

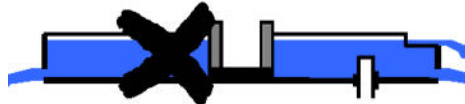

- Check the water overflow

12.1.2.3 Checks when adding salt

- If salt is added using a salt doser, refer to "*Le tube doseur de sel*" (Page 1).
- If a (option)salt doser pump supplied by Geneglace see "*Manual Salt Dosing Pump*".

12.1.3 Refrigeration checks

12.1.3.1 How to adjust the coolant supply



Incorrect adjustment of the coolant supply may cause mechanical malfunctions on the generator and the compressor.



Before using any coolant other than those indicated in this manual, contact Geneglace SAS.

After filling up with coolant and once the supply pressure is constant and close to the average operating conditions, adjust the expansion valve.

Correct adjustment of the coolant supply depends on:

- Filling of the generator with coolant and therefore the ice production.
- Evaporation pressure.

12. First commissioning

- Overheating of the gases sucked in.
- Oil return to the compressor.

Refrigerant supply to generators with reducer

The supply of refrigerant to the generator is achieved by adjusting the refrigerant superheat at the generator outlet.

Overheating is the difference between the contact temperature taken near the bulb or temperature sensor of the expansion valve and the temperature corresponding to the evaporating pressure at the same point.

See the position of the bulb or temperature sensor in the chapter "*Schéma Frigorifique*" (Page 1).

Set the reducer to achieve a superheat of between 6 and 8 K.

Overheating ensures optimal glazing of the cylinder, as well as good oil return.

Problems Encountered	Solutions
Cooling capacity too high	Use a constant pressure valve that can adjust the operating suction pressure.
Excessive overheating	Reducer not open enough or lack of refrigerant
Too little overheating	Reducer is too open
Incorrect oil return	Proper adjustment of the reducer ensures correct oil return.



If you notice any other problems, see the chapter "*Dépannage*" (Page 1).

12.1.3.2 Before first startup

- Check that the cooling circuit is leaktight.
- Check that the pressure reducer bulb or the temperature probe is correctly positioned on the suction tube, securely held and well insulated.
- If an independent cooling circuit is used, in other words a generator connected to a compressor alone, the generator fluid load is indicated in chapter "*Operating conditions*" (on page 46).
- The installer must plan the load for the rest of the circuit.
- Load the installation with coolant

12.1.3.3 Starting your ice machine

- Check that your Geneglace ice machine starts according to the procedure described in chapter "*Operating diagram*" (on page 37)
- Check that the distribution bow is correctly supplied with water.
- Check that the high pressure state is steady.
- Adjust the constant pressure valve to the reference suction pressure of your Geneglace ice generator (if connected to a refrigeration unit).
- Set the regulator overheat 6 to 8 °K see "*Fonctionnement circuit frigorifique*" (Page 1)
- Check that the oil returns to the compressor.

12. First commissioning

12.1.4 Other checks



The ice high level safety device protects the generator but is not a control device.



Never use the ice high level safety device as an ice level detector to control the filling of the tank.

- Check that the ice is scraped off correctly.

If after 30 minutes' operation a lot of noise comes from the generator when scraping off the ice, or if the ice does not scrape off easily, refer to "*Troubleshooting*" (on page 79) and "*Addition of salt*" (on page 48).

- Check that the scrapers operate correctly (no water flowing in the ice tank). To adjust the scrapers, refer to "*Adjusting the scrapers*" (on page 76).
- Simulate the presence of ice to check that the ice level sensors operate correctly.

12.1.4.1 Addition of salt

- Check that the salt addition system operates correctly.

13. Maintenance

13.1 Frequency of servicing and monitoring operations



In the event of earthquakes, bad weather or exceptional events, it is mandatory to check the general good condition of the G15 CO2 generator, its structure and installations before putting it back into service.



Periodic checks should be carried out to ensure that the G15 CO2 generator and its installations are in good condition.



To monitor and maintain your Geneglace equipment, a maintenance logbook is provided with your Geneglace ice machine

Operations	Frequency
Recharge the standard salt doser Fill the brine bottles for the doser pump	Depending on consumption
Compressor oil level Icing up of the suction valve Housing temperature (bottom warm when stopped) Spraying of the cylinder wall Presence of unwanted ice on the reamer Bearings Regular consumption of salt or saline solution	Daily
Clean the water circuit: <ul style="list-style-type: none"> • Base • Bowls • Valve handling 	Weekly
Clean the outside of the generator	Weekly
Clean the standard salt doser	Monthly
Grease the bearings, reamer bearings with a grease pump (With food grade grease in compliance with standards: NSF.H1), contact us if necessary.	Quarterly
Check the operating pressures	Quarterly
Check the operation of the torque limiter contact Check the condition of the scrapers	Quarterly
Check the condition of the insulation and replace it if necessary Check the condition of the cooling pipes (corrosion, chemical attack, etc.) and repair if necessary	Annually
Inspect the gear reducer (signs of oil)	Occasional
Inspect the inner wall of the cylinder to check the level of scaling Presence of a whitish deposit on the dry wall	Occasional



Refer to applicable regulations regarding all other periodic checks to be carried out on your ice production machine.

13.2 Servicing



All assembly and maintenance work must be carried out by qualified personnel in accordance with the regulations in force and all current practices and safety measures of the profession.



The products proposed below have been tested by us and offer full reliability criteria in terms of efficiency and compatibility with Geneglace ice machines



Use of other products (e.g. hydrochloric acid) will permanently damage the generator.



Do not use a water jet and/or high pressure cleaner.

The cleaning products used must be compatible with:

- Stainless steel
- Chromium
- Natural rubber
- EPDM

Over time, certain operating problems due to the water quality may occur on the Geneglace= ice machine.

The two main sources of problems are:

- Proliferation of micro-organisms
- Build-up of scale

We therefore propose a range of descaling and anti micro-organism products.

To guarantee optimum hygiene and correct operation, carry out the following actions regularly:

- The entire outside of the generator **must** be cleaned "*Frequency of servicing and monitoring operations*" (on page 66).
- Dusting and manual washing is recommended to prevent proliferation of bacteria. Do not use a water jet and/or a high-pressure cleaner.

13.2.1 Anti micro-organism product



Read the product safety data sheet before use.

PR 61 is a curative decontaminating sanitary anti-algae product for all microbial contamination.

Description:

It consists of a light coloured liquid.

- Relative density 1.02.
- pH 7.

Composition:

- Alkyl dimethyl benzyl ammonium salt
- Dimethyl benzyl ammonium chloride*
- Organic binders
- Surfactants

* This variety of cationic detergents is authorised in Appendix 1, Products for the cleaning of materials which may come into contact with foodstuffs. Decree of 27 October 1975.

Advantages

- It is hygienic and safe for use.
- It is not volatile.
- It is fast and acts on all surfaces.
- It has a high decontamination power.
- It stops corrosion of the circuit walls attacked by microbial corrosion.

Dosage:

1. Before decontaminating the ice generator, make sure that the ice storage tank is empty.
2. Switch off the machine or switch off the cabinet power supply.
3. Open the base on the water supply side
4. Pour a dose of decontaminating product into the base, according to the table below.
5. Add water up to the base overflow.
6. Close the base.
7. Switch on the machine.
8. Start only: the gear reducer and the pump for about 1 to 2 hours.
9. Stop the operation then drain and rinse 2 or 3 times, switching on the gear reducer and the pump again.
10. Repeat if necessary.

Average dosage 9 g/m³

Generator	Quantity (g)
G15 CO2	0,045

13.2.2 Descaling



Read the product safety data sheet before use.



Do not spill descaling product in the ice tank.



Use of other products (e.g. hydrochloric acid) will permanently damage the generator.

PR 5200 ST (France) is a corrosion inhibitor for cooling circuits.

A data sheet is provided with each bottle, with the instructions for use.

Description:

It consists of a light coloured liquid.

- Relative density 1.23.
- pH 3.5, diluted.

Composition:

- Phosphoric acid preparation
- Zinc chloride

Advantages

- It is not volatile.
- It is fast and acts on all surfaces.
- It has a high descaling power.

Dosage

1. Before descaling the ice generator, make sure that the ice storage tank is empty.
2. Switch off the machine and switch off the electrical cabinet power supply.
3. Open the base on the water supply side
4. Pour a dose of descaling product into the base, according to the table.
5. Add water up to the base overflow.
6. Close the base.
7. Switch on the machine.
8. Start only: the gear reducer and the pump for about 1 to 2 hours depending on the degree of scale.
9. Stop the operation then drain and rinse 2 or 3 times, switching on the gear reducer and the pump again.
10. Repeat if necessary.

Average dilution 7 %

Generator	Quantity (g)	Quantity (L)
G15 CO2	0,3	0,27

13.3 Replacing the wearing parts

For the dismantling, reassembly and adjustment operations, the parts are marked on the exploded views.

The average frequencies are indicated for normal round the clock operating conditions and monitoring according to Geneglace recommendations "*Frequency of servicing and monitoring operations*" (on page 66).

Parts	Frequencies
Float valve	As required
Central shaft bearings	3 years
Torque limiter	2.5 to 3 years
Scrapers	1095 days (3 years)
Water pump	2 days to 3 years possible replacement
reamer and its bearings	3 to 5 years
gear reducer	2 years possible replacement



A maintenance logbook is provided to monitor your ice generator.

13.4 Adjusting the force limiter



13.4.1 Operation of the force limiter

If the ice is not harvested correctly, the torque limiter reacts:

1. The stop **N°2** is compressed by the arm **N°1**
2. The head of screw **no. 3** presses on the roller on the switch arm in front of it and stops the complete installation

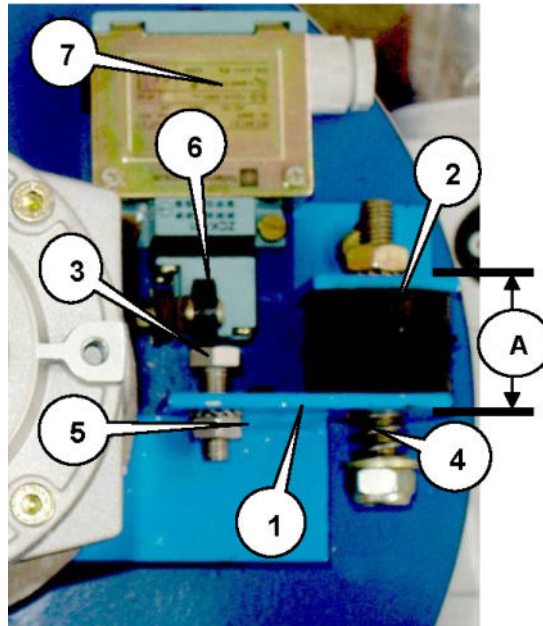

13.4.2 Tools required

- 1 Calliper Gauge
- 1 G-Clamp
- 2 13 mm Flat spanners

13.4.3 Adjustment

1. Measure dimension (**A**) in the drawing above using a calliper gauge.
2. Subtract the following values from the measured dimension:
 - Generator F15: 2,5 mm
3. Take the G-clamp and compress the stop **no. 2** to obtain dimension **A**, minus the value chosen above.
4. Unscrew screw **no. 3** until the switch operates.
5. Remove the G-clamp.
6. Reset the switch (hold the motor-gearbox assembly in your hands and rotate it clockwise in order to decompress stop **no. 2**. The spring **no. 4** facilitates this movement.
7. Take the G-clamp and compress the stop until the switch operates.
8. Measure dimension **A** which must be: dimension **A** minus the chosen value.
9. Hold the head of screw **no. 3** and tighten the nut **no. 5**.
10. Remove the G-clamp.
11. Reset the switch (hold the motor-gearbox assembly in your hands and rotate it clockwise in order to decompress stop **no. 2**. The spring **no. 4** facilitates this movement.

13.5 Adjusting the reamer



Before conducting any work, refer to the manual for the safety instructions and for further information.

13.5.1 Tools required

- 1 set of feeler gauges
- 1 Allen key
- 1 screwdriver
- 1 ratchet wrench with extension
- 1 x 22 mm socket

13.5.2 Adjustment

Plan view

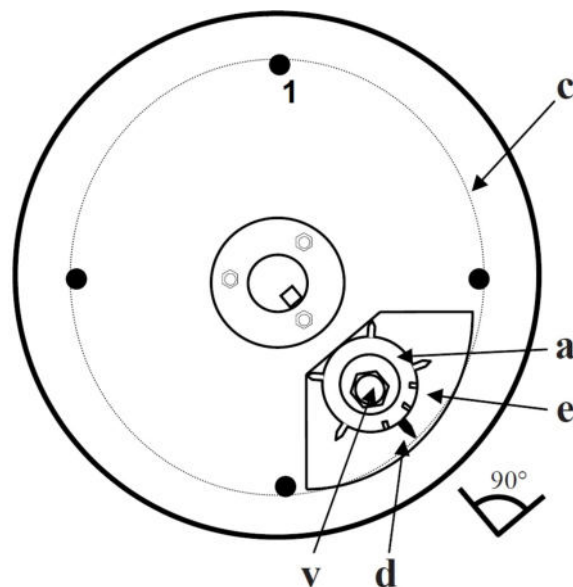

1	Precentring pin
---	-----------------

View from underneath

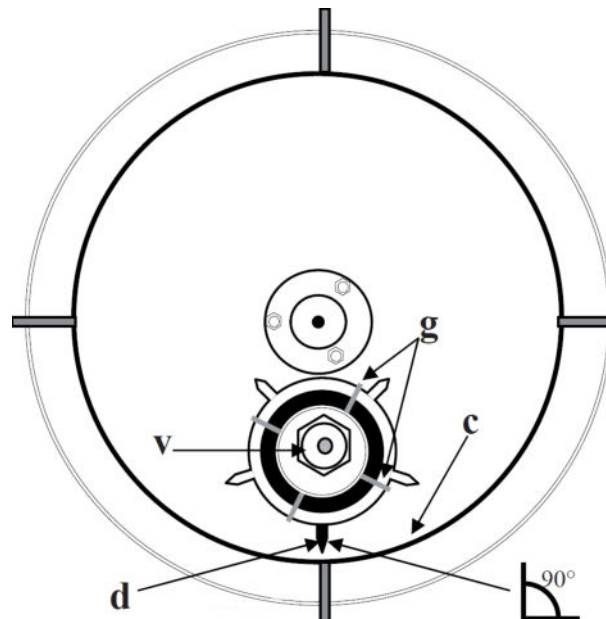

1. Position the reamer opposite the inspection hatch.
2. Select the largest tooth of the reamer using a set of feeler gauges, turning them one after the other perpendicular to the cylinder (c).
3. Loosen the screw (v).
4. Position the selected tooth (d) perpendicular to the cylinder.
5. Turn the reamer axis (a) by placing a screwdriver in one of the notches (e) to rotate clockwise in order to move the reamer tooth away from the cylinder.
6. Turn the reamer axis (a) by placing a screwdriver in one of the notches (e) to rotate anticlockwise in order to bring the reamer tooth closer to the cylinder.
7. Insert a feeler gauge of 0.4 mm or less between the tooth and the cylinder.
8. Turn the reamer axis (a) by placing a screwdriver in one of the notches until the tooth/feeler gauge/cylinder touch each other.
9. Keep this adjustment by blocking the screw (v) while holding the axis (a) with a screwdriver in one of the notches.
10. Take out the feeler gauge by turning the reamer around.
11. To adjust the reamer at the bottom, first loosen the 6 mm Allen screw positioned under the arm blocking the reamer axis.
12. Repeat this principle at the bottom, noting that the notches (e) are replaced by pins (g) which are moved with the fingers.

Turning these pins clockwise move the tooth closer to the cylinder, turning them anticlockwise moves it away from the cylinder.
13. After making the adjustment, tighten the Allen screw to block the reamer axis.

13.6 Adjusting the scrapers



Before conducting any work, refer to the manual for the safety instructions and for further information.

13.6.1 Tools required

- 1 x 10 mm box spanner
- 1 x 10 mm open-ended spanner

13.6.2 Adjustment

The following adjustment principle applies to the front scraper and rear scraper.

In the water distribution bowl, each scraper is positioned by a flat nut and a cap nut blocked together.

1. Using a 10 mm box spanner, turn the front scraper to position **A** and the rear scraper to position **B**. They must remain in these positions.
2. If the two scrapers change position, at the bottom, tighten the lock nuts located underneath the recovery bowl.
A very small trickle of water must be visible at the rear scraper **2**.
3. Positions **C** and **D** cause a deformation by pressing too hard on the cylinder.
4. Positions **E** and **F** create a passage for water in the removal area.
5. Check that the scraper is in good condition by looking underneath the generator.

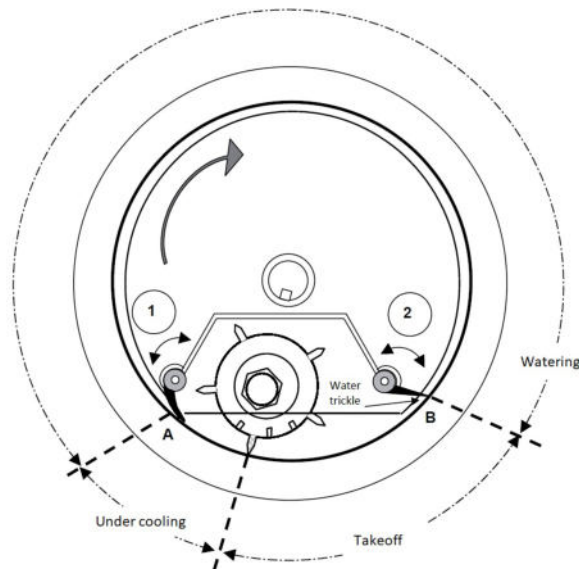

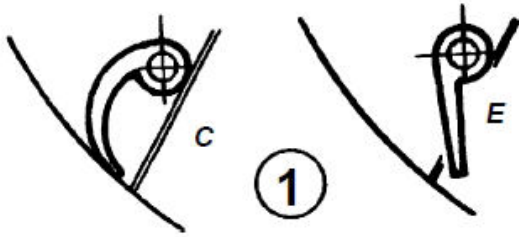

Front scraper

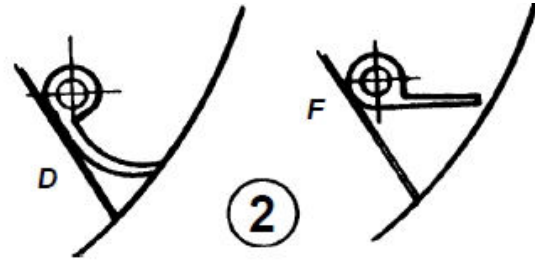

Rear scraper

14. Troubleshooting

The following table will help you diagnose the malfunction observed.

Observations symptoms and effects	Possible causes									
Lower ice production	5	11	12	13	15					
Low pressure abnormally high	12	13	14							
Low pressure abnormally low	11	15	17							
Bubbles in the high pressure liquid indicator	15									
Torque limiter tripped (reamer blocked)	1	2	3	6	8	9	10	17	19	
Low pressure switch tripped	2	6	7	11	15	16	17	18		
High pressure switch tripped	13									
Scraper motor thermal relay tripped	1	2	3	6	8	9	10	19		
Base overflow permanently overflowing	5									
Noisy operation	1	3	6	8	9	10				
Abnormal icing up of the compressor suction valve	2	6	7	8	9	14				
Hard ice, difficult to scrape off the cylinder and coming off in 2 thicknesses	8	9	10							
Thin, transparent, wet ice, coming off in 2 thicknesses	5	12								
Granular ice surface on one side (orange-peel)	2									
Irregular ice with drips	6									
Ice located in the bottom of the cylinder and/or thick	6	11								
Block of ice building up under the machine	3	4	11	16	17					
Ice difficult or impossible to detach as the reamer goes past	1	2	12							
Thick, soft ice which does not come off the cylinder	2									
Highly fragmented ice	1	17								
gear reducer out of service	19									
Compressor oil level low	11									
Compressor oil level high when starting, then low afterwards	18									

14. Troubleshooting

Possible causes	
1	Not enough salt
2	Too much salt
3	Front scraper badly set or damaged (water leak)
4	Rear scraper badly set or damaged (water leak)
5	Float valve blocked open or closing completely, float damaged
6	Insufficient water distribution: hole blocked, pump discharge rate low (pump unprimed or damaged)
7	No water distribution: water switched off, float valve blocked, closed? pump fault
8	Reamer too far from the cylinder
9	Play in shaft bearings, incorrect centring
10	Cylinder scaled up
11	Oil or lack of coolant in the double wall: excessive overheating, coolant leak, partial blocking of the liquid line, pressure reducer filter dirty
12	Insufficient cooling power: dirty condenser, ambient temperature high, compressor check valves worn, dirty compressor filter
13	Dirty compressor, ambient temperature high
14	Pressure reducer temperature increase too low
15	Insufficient coolant, coolant leak
16	Condensation too low
17	Excessive cooling power (evaporation too low)
18	Compressor housing resistor out of service
19	torque limiter badly adjusted or out of service

15. Exploded views

15.1 External Parts

This drawing is the property of Geneglace SAS. It may not be reproduced or communicated to a third party without our authorisation

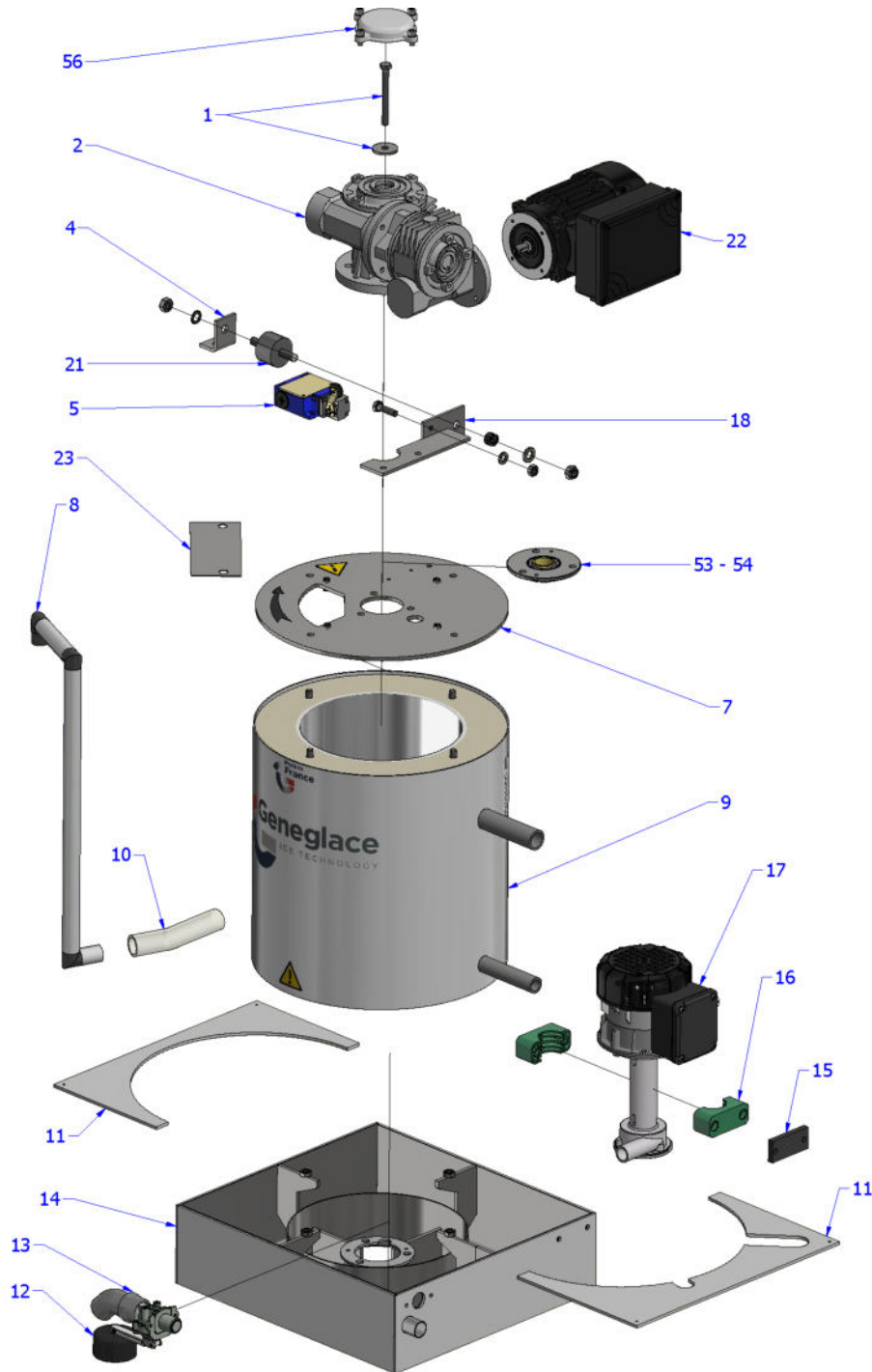

Ref.	Designation	Qty.
1	Screw + washer	1
2	Gear reducer	1
4	Torque limiter bracket	1
5	Torque limiter contact housing	1
7	Top partG15 CO2	1
8	Water supply tube G15 CO2	1
9	Cylinder G15 CO2	1
10	Water tube hose	1
11	Base cover (2 elements)	1
12	Float valve	1
13	Valve	1
14	Base G15 CO2	1
15	Pump wedge G15 CO2	1
16	Pump collar G15 CO2 (2 elements)	1
17	Water Pump	1
18	Reaction arm G15 CO2	1
21	Torque limiter plot	1
22	Scraper motor	1
23	Inspection hatch	1
53	Spherical plain bearing	2
54	Spherical plain bearing housing	2
56	Bonnet	1

15.2 Internal Parts

This drawing is the property of Geneglace SAS. It may not be reproduced or communicated to a third party without our authorisation

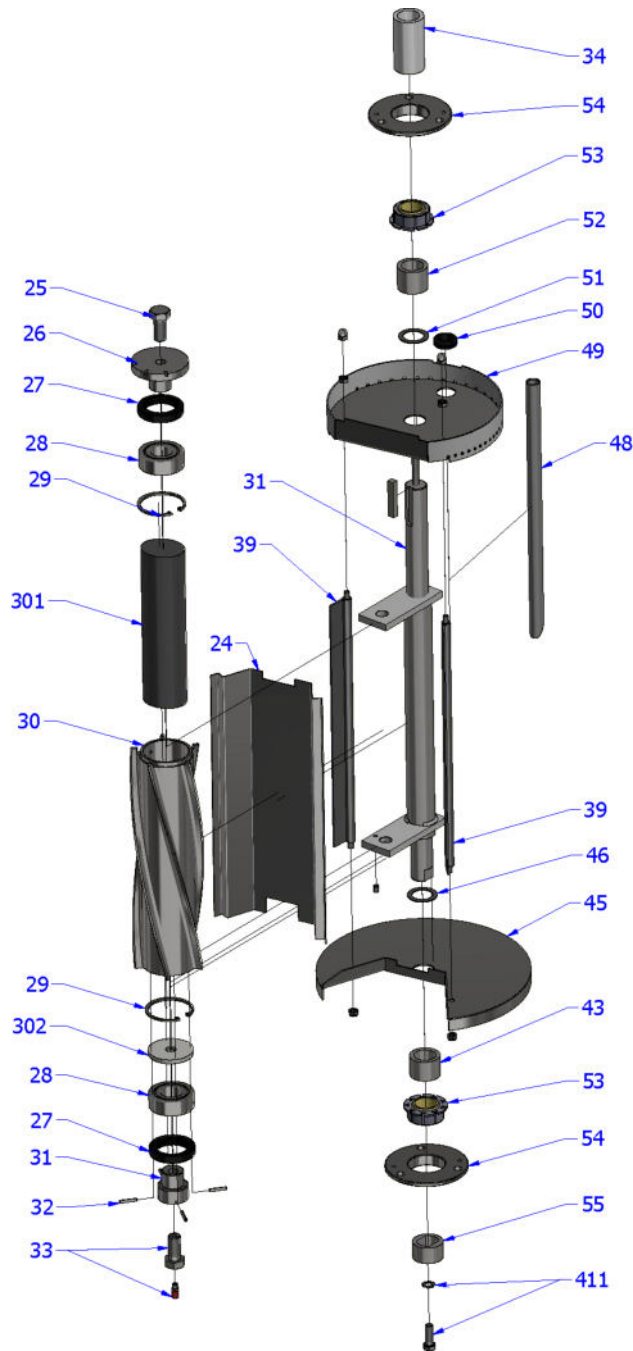

Rep.	Designation	Qty.
25	Screw for upper reamer shaft	1
26	Upper reamer shaft	1
27	Seal	2
28	Bearing	2
29	Circlips	2
30	reamerG15 CO2	1
301	reamer core G15 CO2	1
302	Disassembly washer	1
31	Lower reamer shaft	1
32	Adjusting pin	4
33	Greasing screw for lower reamer shaft	1
34	Gear reducer spacer for G15 CO2	1
39	Scraper for G15 CO2	2
411	Screw + Locking washer Ring Shaft for G15 CO2	1
43	Spacer low shaft bearing for G15 CO2	1
45	Recovery bowl G15 CO2	1
46	Recovery bowl seal G15 CO2	1
48	overflow tube from recovery bowl G15 CO2	1
49	Distribution bowlG15 CO2	1
50	Wire pass	1
51	Distribution bowl seal G15 CO2	1
52	Distribution bowl spacer G15 CO2	1
53	Spherical plain bearing	2
54	Spherical plain bearing housing	2
55	Shaft ring G15 CO2	1

16. First commissioning sheet



Before conducting any work, refer to the manual for the safety instructions and for further information.

This inspection sheet is used to check the main points when installing a generator to ensure it operates correctly.

Tick the boxes o as you proceed with the inspection:

16.1 Check before powering up

- Check that the base is secure and watertight (flat and level).
- Check that the base is fixed properly and watertight (silicone seal around the ice outlet).
- Check that the diameter of the ice chute (if any) (according to manual).
- Check that the possibility of dismantling this chute for future servicing.
- Check that the ice chute is not in the air supply of an evaporator.
- Check the position of the ice level safety pallet (according to manual) and the electrical connection of the contact.
- Check the presence of the exchanger on the suction system for the G15 CO2 generator (according to manual).
- Check the position and insulation of the pressure and temperature sensors and their isolation (according to manual).
- Check the connection of the overflow to the drain.
- Check that the float valve can move freely.
- Check the water level in the generator base when stopped (according to manual).
- Check that the gear reducer coupling.
- Check the electrical connection of the torque limiter.
- Check the presence of a "work" timeout (delay when starting) on the reducer and water pump control (if the generator is connected to a refrigeration unit).
- Check the presence of a "standby" timeout (delay when stopping) on the gear reducer control.

16.2 Check after powering up

- According to the manual, trigger the torque limiter manually (complete shutdown of the generator and its associated unit), then reset it.
- Check the scraper direction of rotation (shown by the arrow painted on the top - clockwise).
- Check the operation and setting of the doser pump (if any).

16. First commissioning sheet

- Check the operation of the ice high level detection safety device.
- Check the operation of the regulation detection.
- Adjust the injection time delay (T1) if the machine is connected to a refrigeration unit.
- Adjust the cylinder cleaning time delay (TKA 1) to 180 s.
- Pre-fill the cooling circuit after draining.

16.3 Check after starting up

- As soon as the liquid solenoid valve is activated, time the filling time of the cylinder (see suction outlet icing) (Connection to refrigeration unit).
- Defer this time to the injection time delay (T1) (value to be adjusted if necessary).
- Check that the scrapper and water pump are switched on after this time delay.
- Check the stability of the high-pressure system. (stable ventilation)
- Check the setting of the constant pressure valve (if existing) in order to obtain the pressure recommended when selecting the generator.
- Check that the scrapper are working properly (according to the instructions).
- Check the water level in the upper bowl and the level in the base (according to the instructions).
- Check the oil level at the sight glass of the compressor (also check later).

16.4 After 20 to 30 minutes' operation, check:

- The water level in the base (according to manual) (that no water drains out of the overflow tube)
- Removal of the ice without the gear reducer moving.
- The drip of the doser pump (if any).
- The oil level return shown by the compressor indicator lamp (depending on the type of installation, it may be necessary to top up with oil).
- The operating pressures (depending on the production defined).
- Stop the G15 CO2 generator with the Stop button.
- Check the water level in the base (according to manual) (that no water drains out of the overflow tube when the generator is stopped).
- Switch on the installation again and complete the operation checklist.

17. CE Declaration of Conformity

 ENR-TRA-006-Fr
vE

DECLARATION D'INCORPORATION

Selon la Directive Machines 2006/42/CE Annexe IIB.

Le fabricant: Geneglace SAS ZAC de la Forêt - 9, Rue des Orfèvres 44840 LES SORINIÈRES - FRANCE		
Déclare que l'équipement désigné ci-dessous,		
Générateur glace écaïlle type:		N° Série:
N° Affaire:		
. Ne pourra être mis en service avant que la machine dans laquelle il sera incorporé ne soit déclarée conforme aux dispositions de la Directive 2006/42/CE modifiée.		
. Les normes européennes harmonisées suivantes doivent être observées: EN ISO 12100-1, EN 292-2, EN 294, EN 349, EN 418		

DECLARATION "UE" DE CONFORMITE

Selon les Directives 2004/108/CE et 73/23/CE.

Le fabricant: Geneglace SAS ZAC de la Forêt - 9, Rue des Orfèvres 44840 LES SORINIÈRES - FRANCE		
Déclare que l'équipement désigné ci-dessous,		
Générateur glace écaïlle type:		N° Série:
N° Affaire:		
. Est conforme aux dispositions de la Directive "Compatibilité électromagnétique" 2014/30/UE modifiée.		
. Est conforme aux dispositions de la Directive Européenne "Basse tension" 2014/35/UE modifiée.		
. Est conforme aux dispositions des Normes Européennes harmonisées suivantes: EN 60204-1, EN 50081-1, EN 50082-1, EN 378-2		
. Est conçu et fabriqué conformément aux règles de l'art selon l'article 3§3 de la Directive 2014/68/UE relative aux équipements sous pression, suivant le code de construction CODAP2000 Cat.B-CODET12001.		

 Fait à Les Sorinières, le:
Serge Vidal
Président



Geneglance SAS

9 Rue des Orfèvres
44840 Les Sorinières

France

Tél : +33 2 51 19 10 51

Mail : contact@geneglance.com

Web : www.geneglance.com

